

KANNUR UNIVERSITY

(Abstract)

B.Sc Electronics-Scheme & Syllabus of Core/Complementary/Common/Open Courses under Choice Based Credit Semester System for Under Graduate Programme- implemented with effect from 2009 admission-Orders Issued.

ACADEMIC BRANCH

No.Acad/C2/8966/2008.

Dated, K.U.Campus. P.O 10-07-2009.

- Read: 1.Minutes of the meeting of the Board of Studies in Electronics (Cd) held on 26-05-2009.
2. Minutes of the meeting of the Faculty of Science held on 16-06-2009.
3. U.O No.Acad/C2/3838/2008 (i) dated 07-07-2009.
4. Letter dated 02-07-2009 from the Chairman, BOS in Electronics (Cd).

ORDER

1.The Board of Studies in Electronics (Cd) vide paper read(1) above has prepared, finalised and recommended the Scheme and Syllabus of Electronics Core/Complementary/Open Courses along with the Model Question Papers and Common Courses for LRP Programmes under Choice Based Credit Semester System for implementation from 2009 admission.

2. The recommendations of the Board in restructuring the syllabus is considered by the Faculty of Science vide paper read (2) and recommended for the approval of the Academic Council.

3. The Regulations for Choice based Credit Semester System is implemented in this University vide paper read (3).

4. The Chairman, BOS in Electronics(Cd),vide paper read (4) forwarded the restructured scheme and syllabus of Electronics Core/Complementary/Open Courses along with the Model Question Papers and Common Courses for LRP Programmes under Choice Based Credit Semester System, prepared by the Board of Studies in Electronics (Cd) for implementation with effect from 2009 admission.

5. The Vice Chancellor, after examining the matter in detail, and in exercise of the powers of the Academic Council as per section 11(1) of Kannur University Act 1996 and all other enabling provisions read together with, has accorded sanction to implement the scheme and syllabus of Electronics Core/Complementary/Open Courses along with the Model Question Papers and Common Courses for LRP Programmes restructured in line

with Choice Based Credit Semester System, with effect from 2009 admission, subject to ratification by the Academic Council.

6. The restructured scheme and syllabus of Electronics Core/Complementary/Open Courses and Common Courses for LRP Programme along with Model Question Papers under Choice Based Credit Semester System, implemented with effect from 2009 admission is appended.

7. The Scheme and Syllabus of Complementary Courses offered for this Programme will be available along with the syllabus of Core Courses of the Complementary subject.

8. The affiliated Colleges are not permitted to offer Complementary Courses in violation to the provisional/permanent affiliation granted by the University. Changes in Complementary Courses are permitted with prior sanction /revision in the affiliation order already issued in this regard.

9. If there is any inconsistency between the Regulations for CCSS and its application to the Scheme & Syllabus prepared, the former shall prevail.

10. Orders are issued accordingly.

To:

Sd/-
REGISTRAR

1. The Principals of Colleges offering Electronics Programme
2. The Examination Branch (through PA to CE)

Copy To:

1. The Chairman, BOS Electronics (Cd)
2. PS to VC/PA to PVC/PA to Regr
3. DR/AR I Academic
4. Central Library
5. SF/DF/FC.

Forwarded/By Order

SECTION OFFICER



KANNUR UNIVERSITY

SCHEME & SYLLABUS

FOR UNDERGRADUATE PROGRAMME IN ELECTRONICS

CORE ,COMPLEMENTARY & OPEN COURSES

CHOICE BASED CREDIT SEMESTER

SYSTEM

w.e.f 2009 ADMISSION

Programme Objective

There are two main objectives to the B.Sc Electronics Programme.

- a) To produce electronic professionals who can be directly employed or start his/her own work as Electronic circuit Designer, Electronics consultant, Testing professional, Service engineer and even an entrepreneur in electronic industry.
- b) To train students to a level where they can readily compete for seats for advanced degree courses like MSc (Electronics) and MBA etc.

On completion of the B.Sc Electronics Programme, the student will:

- Have basic communicative skill in the English language
- Have environmental and civic awareness
- Communicative skills and literary sensibility in languages other than English
- Have sound knowledge of the theory behind core subjects like, Electronic components, Electronic measuring and testing instruments, Analog and Digital IC's, Electronic circuit design and implementation, Troubleshooting and maintenance of electronic and electrical devices.
- Have sound skills in assembly Language and High Level Language programming, Interfacing of electronic devices with computers, etc
- Be in a position to develop industrial and entrepreneur applications

COURSE STRUCTURE FOR UG PROGRAMME ELECTRONICS

SEMESTER 1

No	Title of the Course	Hours /week	Credits	Exam hrs
1	Common Course (English)	5	4	3
2	Common Course (English)	4	3	3
3	Common Course (Additional Language)	4	4	3
4	Core Course 1	4	3	3
5	Complementary 1 (Course I)	4	3	3
6	Complementary 2 (Course I)	4	3	3

SEMESTER 2

No	Title of the Course	Hours/week	Credits	Exam hrs
1	Common Course (English)	5	4	3
2	Common Course (English)	4	3	3
3	Common Course (Additional Language)	4	4	3
4	Core Course 2	4	3	3
5	Complementary 1 (Course II)	4	3	3
6	Complementary 2 (Course II)	4	3	3

SEMESTER 3

No	Title of the Course	Hours/week	Credits	Exam hrs
1	Common Course (English)	5	4	3
2	Common Course (Additional Language)	5	4	3
3	Core Course 3	5	4	3
4	Complementary 1 (Course III)	5	3	3
5	Complementary 2 (Course III)	5	3	3

SEMESTER 4

No	Title of the Course	Hours/week	Credits	Exam hrs
1	Common Course (English)	5	4	3
2	Common Course (Additional Language)	5	4	3
3	Core Course 4	5	4	3
4	Complementary 1 (Course IV)	5	3	3
5	Complementary 2 (Course IV)	5	3	3

SEMESTER 5

No	Title of the Course	Hours / week	Credit	Exam hrs
1	Open Course 1	2	2	3
2	Core Course 5	3	3	3
3	Core Course 6	3	3	3
4	Core Course 7	3	3	3
5	Core Course 8	7	5	3
6	Core Course 9	7	5	3

SEMESTER 6

No	Title of the Course	Hours / week	Credit	Exam hrs
1	Open Course 2	2	2	3
2	Core Course 10	3	3	3

3	Core Course 11	3	3	3
4	Core Course 12	3	3	3
5	Core Course 13	3	3	3
6	Core Course 14	7	5	3
7	Project	4	4	*

The distribution of Hours/Credits for Complementary Theory/Practical shall be decided by the Board of Studies concerned.

COURSE STRUCTURE FOR UG PROGRAMME ELECTRONICS (*LRP Scheme*)

SEMESTER 1

No	Title of the Course	Hours /week	Credits	Exam hrs
1	Common Course (English)	5	4	3
2	Common Course (English)	4	3	3
3	Common Course (Additional Language)	5	4	3
4	Core Course 1	3	3	3
5	Complementary 1 (Course I)	4	3	3
6	Complementary 2 (Course I)	4	3	3

SEMESTER 2

No	Title of the Course	Hours/week	Credits	Exam hrs
1	Common Course (English)	5	4	3
2	Common Course (English)	4	3	3
3	Common Course (Additional Language)	5	4	3
4	Core Course 2	3	3	3
5	Complementary 1 (Course II)	4	3	3
6	Complementary 2 (Course II)	4	3	3

SEMESTER 3

No	Title of the Course	Hours/week	Credits	Exam hrs
1	Common Course (Numerical Techniques)	5	4	3
2	Common Course (Methodology and Perspective of Science)	5	4	3
3	Core Course 3	5	4	3
4	Complementary 1 (Course III)	5	3	3
5	Complementary 2 (Course III)	5	3	3

SEMESTER 4

No	Title of the Course	Hours/week	Credit	Exam hrs
1	Common Course (Cyber Law and Human Rights)	5	4	3
2	Common Course (Principles of Management)	5	4	3
3	Core Course 4	5	4	3
4	Complementary 1 (Course IV)	5	3	3
5	Complementary 2 (Course IV)	5	3	3

SEMESTER 5

No	Title of the Course	Hours / week	Credit	Exam hrs
1	Open Course 1	2	2	3
2	Core Course 5	3	3	3
3	Core Course 6	3	3	3
4	Core Course 7	3	3	3
5	Core Course 8	7	5	3
6	Core Course 9	7	5	3

SEMESTER 6

No	Title of the Course	Hours / week	Credit	Exam hrs
1	Open Course 2	2	2	3
2	Core Course 10	3	3	3
3	Core Course 11	3	3	3
4	Core Course 12	3	3	3
5	Core Course 13	3	3	3
6	Core Course 14	7	5	3
7	Project	4	4	*

The distribution of Hours/Credits for Complementary Theory/Practical shall be decided by the Board of Studies concerned.

Common Courses offered in III & IV Semesters for LRP Scheme

3A01ELE Numerical Techniques

3A02ELE Methodology and Perspective of Science

4A03ELE Cyber Law and Human Rights

4A04ELE Principles of Management

Scheme Core (Electronics)

No	Semester	Course Code	Title of the Course	Hours/Week	Credit
1	I	1B01ELE	Methodology and Theory of Electronic devices	2	2
2	I	1B01PELE	Electronic Devices Lab	*2	1
3	II	2B02ELE	Electronic Circuits	2	2
4	II	2B02PELE	Electronic Circuits Lab	*2	1
5	III	3B03ELE	Digital Electronics	3	3
6	III	3B03PELE	Digital Electronics Lab	2	1
7	IV	4B04ELE	Analog Integrated Circuits	3	3
8	IV	4B04PELE	Analog Integrated Circuits Lab	2	1
9	V	5B05ELE	Network Theory	3	3
10	V	5B06ELE	General informatics and Informatics specific to Electronics	3	3
11	V	5B07ELE	Electronic Instrumentation	3	3
12	V	5B08ELE	Microprocessors	3	3
13	V	5B08PELE	Microprocessor Lab	4	2
14	V	5B09ELE	Electronic Communication I	3	3
15	V	5B09PELE	Communication System Lab	4	2
16	VI	6B10ELE	Electro Magnetic Theory	3	3
17	VI	6B11ELE	Digital Signal Processing	3	3
18	VI	6B12ELE	Microwave techniques and Radar	3	3
19	VI	6B13ELE	Electronic Communication II	3	3
20	VI	6B14ELE	Microcontrollers	3	3
21	VI	6B14PELE	Microcontroller Lab	4	2

22	VI	6B15ELE	Project Work	4	4
----	----	---------	--------------	---	---

There shall be theory and Practical examinations at the end of each semester. The Practical examination of Odd semesters shall be conducted internally and the Practical examination for Even semesters shall be conducted by the University.

** For LRP Scheme, 1Hour/Week is allotted.*

Scheme Complementary (Electronics)

No	Semester	Course Code	Title of the Course	Hours/Week	Credit
1	I	1C01ELE	Basic Electronics	2	2
2	I	1C01PELE	Basic Electronics Lab	2	1
3	II	2C02ELE	Digital Electronics	2	2
4	II	2C02PELE	Digital Electronics Lab	2	1
5	III	3C03ELE	Communication System	3	2
6	III	3C03PELE	Electronic Circuits Lab	2	1
7	IV	4C04ELE	Microprocessor & Peripherals	3	2
8	IV	4C04PELE	Microprocessor Lab	2	1

Scheme Open Courses

No	Semester	Course Code	Title of the Course	Hours/Week	Credit
1	V	5D01ELE	A.P C Hardware	2	2
2	V	5D02ELE	B.Opto electronics	2	2
3	VI	6D01ELE	A.Power electronics	2	2
4	VI	6D02ELE	B.Mobile Computing	2	2

Web Resources

Students are generally advised to make use of the resources available on the internet. Some useful links related to electronics are given below.

1. M.I.T. open course ware video lectures are available at
<http://ocw.mit.edu/OcwWeb/Electrical-Engineering-and-Computer-Science/6-002Spring-2007/VideoLectures/index.htm>
2. www.electronics-tutorials.com
3. <http://electronics.howstuffworks.com>
4. www.science-ebooks.com/electronics
5. <http://computer.howstuffworks.com>
6. www.geocities.com/CapeCanaveral/1221/elec1.htm
7. <http://101science.com/eleclinks.htm>
8. www.electro-tech-online.com/blogs/gayan-soyza/23-useful-electronic-links.html
9. www.discovercircuits.com/resources/tutorials.html
10. www.electronics-lab.com/
11. www.glolab.com/links/links.html etc

Sd/-
Dr. K. P.Santhosh,
Chairman, BOS Electronics

(Cd)

Semester : 1
Hrs/Week :2
Core course
Credits : 2

1B01 ELE - METHODOLOGY AND THEORY OF ELECTRONIC DEVICES

Aim of the Course

To equip the students with basic components in electronics, identifying and testing them, familiarize with various measuring and testing instruments, assembling of electronic

circuits and basic techniques of troubleshooting.

Objectives of the Course

- To learn the basics of electronic components
- To learn the basics of testing and measuring instruments
- To learn the circuit assembling
- To study circuit troubleshooting

Course Outline

Module I What is Electronics - Revolutions in science & Technology - Revision of basic theories & laws [Resistors, capacitors, inductors]

Necessity of units & dimensions

Scientific instruments, accuracy & precision

Scientific research : Aim & motivation, Principles & ethics

Literature survey : Access using internet web tools.

Application software : Basic ideas of PSPICE, Math lab and Mathematica

Module II: Crystallography Definition of crystal structures – Transitional of vectors - symmetry operations - Primitive lattice cell & unit cell - Fundamental types of lattices - Two dimensional lattice types - Bravais lattice – Diamond structures – X ray diffraction – Bragg's law – Crystal imperfection – Point defects – Schottky & Frenkel defects.

Conduction in semiconductor The energy band theory of crystals – insulators – semiconductors & metals, electrons and holes in semiconductor - conductivity of semiconductors - carrier concentration in intrinsic semiconductor - Doping - charge densities in a semiconductor – Fermi level in extrinsic semiconductor – Diffusion - continuity equation - Hall effect & magnetic field, potential energy.

Module III Semiconductor diode - PN junction - step junction - graded junction - contact potential - forward and reverse bias junction - minority and majority carrier currents - current voltage relation - reverse bias - breakdown - reverse recovery, Zener diode, varactor diode, tunnel diode and LED - solar cell.

Polar junction transistor : - transistor action - minority carrier distribution - evaluation of terminal current - current transfer ratio - coupled diode model - switching characteristics - base narrowing - emitter crowding - transistor small signal model - transistor configuration & characteristics.

Module IV Field effect transistor :- Junction FET - terminal current - pinch of voltage – transconductance model - metal oxide semiconductor FET,- MOS capacitor - threshold voltage - current voltage relation - transconductance short channel effect - Construction & characteristics of VJT, DIAC, TRIAC, SCR.

Text Books

1. J Anderson, B H Durston and M Poole, Theories and Assignment writing - Wiley Eastern Delhi
2. Internet: An introduction, CI systems School of computing, Jaipur, TMH Delhi
3. William H Press, Saul A Tenkolsky, William Vettuling and Brian P. Flannery, Numerical recipes : The art of scientific computing (Cambridge University Press 2007)
4. Applied electronics – R. S. Sedha Khanna

5. Integrated electronics – Milman & Halkias, TMH
6. Electronic devices and Circuit theory - Boylstal & Nehlasky, PHI
7. Solid state electronics devices – Ben. G. Streetman.
8. Hunt, Lipsman, Rosenberg, A Guide to Matlab, Cambridge

References

1. <http://www.computer.howstuffwork.com>.
2. http://www.electronics_tutorials.com
3. <http://www.electronics.howstuffworks.com>.

Semester : 1

Hrs/Week :1

Core course

Credits : 1

--

1B01PELE - ELECTRONIC DEVICES LAB

1. Familiarization of components (Resister , capacitor, transformers)
2. Study of measuring instruments - CRO , Function generator , Millimeter (Digital / Analog) , Power supplier
3. Soldering practice through simple circuits
4. PCB Fabrication
5. Characteristics V- I
 - a) Rectifier diode - silicon/ Germanium
 - b) Light Emitting diode
 - c) Zener diode
 - d) Photo diode
 - e) LDR
6. Transistor characteristics
 - a) C –B configuration
 - b) C-E configurationMeasurement of current gain, voltage gain, Z_{in} , Z_{ont}
7. FET characteristics – transcontuctance, Z_{ont} , Amplification factor
8. UJT characteristics –Intrinsic stand off ratio, peak point, valley point

9. SCR characteristics – Break over voltage.

References

1. T.D. Kuryachan & Shyam Mohan S, "Electronics Lab Manual, Vol. I", Ayodhya Publications
2. Walter C. Bosshart, "Printed Circuits Board Design and manufacturing", Tata McGraw-Hill Publishing LTD.
- 3.

Semester : 2

Hrs/Week :2

Core course

Credits : 2

2B02ELE - ELECTRONIC CIRCUITS

Aim of the Course

To equip the students with basic components in electronics, identifying and testing them, to familiarize with various measuring and testing instruments, assembling of electronic circuits and basic techniques of troubleshooting.

Objectives of the Course

- To learn fundamentals of electronics
- To learn the circuit assembling
- To study circuit troubleshooting

Course Outline

Module I Fundamental of AC - current, voltage and power relation ship - Principle of transformers – Rectifiers - Half wave and full wave – ripple factor – Efficiency – Filters – Capacitor filter LC, CLC, induction filter - voltage regulators

Module II : BJT amplifier Concept of amplification – Biasing circuits – Hybrid equivalent circuits - RC coupled amplifier - frequency response – Calculation of voltage and current gain - input & out put impedances - concept of gain - band width product – emitter follower – typical circuits and application

FET amplifiers: - Principle of operation - biasing circuits - FET small signal model - comparison BJT & FET

Module III : Feed back amplifier Concept of positive & negative feed back in amplifiers - characteristic of negative feed back amplifier - different types of feed back – applications – familiarisation of typical feed back amplifier circuits.

Large signal amplifier Concept of power amplification - Class A, Class B, Class C and Class AB amplifiers - types of distortions in power amplifiers -Typical power amplifier circuits - principles of operation -transistor rating – Use of heat sinks.

Module IV : Oscillator Principle of sinusoidal oscillation - Barkhausen criteria - RC oscillators - LC oscillators -Crystal oscillators - typical circuits - principle of operation - derivation of equation for frequency of oscillation - Application.

Pulse & wave shaping circuit

Differentiating & integrating circuits - sweep circuit - Miller & Boot Strap sweep circuits - clipping & clapping circuit – multivibrators - principle of operation - out put wave forms and applications.

Text Books

- 1) Electronic Devices & Circuit theory – Boyleston & Nehlasky, PHI
- 2) Integrated Electronics – Millman & Halkies, TMH
- 3) Electronic Devices & Circuits - A Mottershed
- 4) Basic Electronics & Linear circuits – Bhargava
- 5) Micro Electronics – Millman & Grabel

References

- 1) www.electronics_tutorials.com
- 2) www.science_ebooks.com/electronics
- 3) www.electronics.howstuffworks.com.

Semester : 2

Hrs/Week :1

Core course

Credits : 1

-

2B02PELE - ELECTRONIC CIRCUITS LAB

1. Rectifier a) Half wave (without filter & with simple capacitor filter)

b) Full wave (centre tap, Bridge)

Evaluate ripple factor, Effecting, PIV

2. Biasing circuits a) Fixed bias

b) Fixed Bias with Emulator resistance

c) Voltage divider

Design, fixing the operating point, DC Load Line

3. RC coupled Amplifier BJT - Design, Find AC voltage gain, Z_{in} , Z_{out}
Plot Frequency Response, Band width
4. FET Amplifier (self Bias)
Design, AC voltage gain, Z_{in} , Z_{out} , Frequency response plot, Band width
5. Feed back Amplifier a) current series feedback
b) Voltage series feedback
Design, Frequency response, Band width
6. RC phase shift oscillator - Design, Measurement of frequency
7. Wein Bridge oscillator - Design, measurement of frequency
8. Astable Multivibrator
Design, Measurement of frequency, plot of waveforms.
9. Mono stable Multivibrator
Design, Output wave forms
10. Clipping & clamping circuits
11. Sweep circuits
12. Voltage Regulator – Zener diode
13. Schmitt Trigger

References

1. T.D.Kuryachan & Shyam Mohan S.,” Electronics Lab Manual Vol-I”, Ayodhya publications.

Semester : 3

Hrs/Week :3

Core course

Credits : 3

3B03ELE - DIGITAL ELECTRONICS

Aim of the Course

To equip the students with detailed knowledge in digital electronics, digital IC's in the 74XX series. Many of the ideas are important to learn microprocessors.

Objectives of the Course

- To learn different number systems, logic gates, comparators, flip flops etc

Course Outline

Module I Number systems – Decimal, Binary, Octal & Hexadecimal – conversions, Digital codes – BCD, Excess 3, Gray code, ASCII Code - Error detection codes – conversions, Boolean algebra & theorems, SOP & POS, De Morgan's theorem, simplification of Boolean Algebra & K Map, Logic gates.

Module II Comparison of Logic families - TTL, CMOS, ECL & its characteristics study, combinational circuits - Adders, Subtractors, comparators, De-coders, En-coders, MUX & De-MUX, parity generators – Familiarisation of popular ICs .

Module III Sequential circuits - Flip-flop [R-S latch, clocked R-S, D, J-K, T, Master slave], Shift registers & applications, Asynchronous counter, synchronous counter, Ring counter, ripple counters, counter design and sequence generator.

Module IV Converters -ADC & DAC [Different types], Parameters, performance comparison & Application, Display – LED (seven segments) & LCD.

Text books

1. Thomas Floyd, Digital fundamentals

References

1. Digital principles and applications by Malvino & Leach
2. Digital electronics circuits & systems, V. K. Puri, TMH
3. Digital integrated electronics, Taub & Schilling
4. Digital integrated circuits, Millman

Semester : 3

Hrs/Week :2

Core course

Credits : 1

3B03PELE - DIGITAL ELECTRONICS LAB

1. Familiarization of logic gates
2. Realization of gates using NAND & NOR
3. Adders & subtractions
 - Half adder subtractions

- Full adder subtractions
- 4. Multiplexers IC -74151
- 5. Demultiplexer - using IC
- 6. Decoders & encoders using IC [BCD to decimal decoder, BCD to seven segment decoder]
- 7. Parity generators & checkers using IC
- 8. Latches & flip – flop
(SR & JK)
- 9. Counters –Asynchronous binary counter - 7493
Decode counter – 7490
- 10. Shift Registers
- 11. Johnson counter & Ring counter
- 12. Multivibrators (using discrete gates)

Semester : 4

Hrs/Week :3

Core course

Credits : 3

--

4B04ELE - ANALOG INTEGRATED CIRCUITS

Aim of the Course

To equip the students with detailed knowledge of Analog IC's like OPAMP 741, IC 555 etc.

Objectives of the Course

- To learn the basics of Amplifiers, filters, wave form generators, comparators, multivibrators and voltage regulators

Course Outline

Module I Operational amplifier: Basic differential amplifier analysis, block diagram representation of typical op-amp parameters, inverting & non inverting amplifiers, voltage follower, current mirror, cascade & cascode amplifier.

Op-amp circuits: Summing amplifier, differential amplifier, instrumentation amplifier, integrator, differentiator, logarithmic & antilogarithmic amplifier, typical circuits and applications.

Module II Active filters: Introduction, simple circuits & explanation of low pass, high pass, band pass, band reject & all pass filters, typical circuits and applications.

Waveform generators: sine wave oscillators, multivibrators, triangular wave generators, voltage controlled oscillators (VCO).

Module III Timers & their applications, principle of operation, typical circuits, applications, popular IC versions

Voltage regulators: basic circuits, configuration & characteristics of voltage regulators, basic blocks of linear voltage regulators, concept of three terminal fixed regulators and switching regulators & SMPS, typical circuits, applications.

Module IV Voltage comparators: basic comparators characteristics, typical comparator circuits using Op-amp, comparators ICs, different types of comparators, Schmitt trigger, typical circuits, principle of operations, applications.

Multipliers, modulators & demodulators: analog multiplier, application of multipliers, modulators & demodulators, balanced modulators, principle and applications, typical circuits, principle of operation, applications.

Phase locked loops: Operating principle of the PLL, lock range and capture range, major building blocks of PLL, typical ICs, typical circuits, applications, popular ICs.

Text books

1. OP-AMPS & linear ICs, Gaykwad
2. Integrated circuits, Boltkar

References

1. Integrated electronics, Millman & Halkias
2. Electronic devices & circuits, Mottershed
3. OP-AMP design & applications, Tobey & Huelsman

Semester : 4

Hrs/Week :2

Core course

Credits : 1

--

4B04PELE - ANALOG INTERGRATED CIRCUITS LAB

1. OP – AMP – Non inverting & inverting Amplifier (AC & DC)
2. Adding & subtractor (DC only)
3. OP –AMP parameters
CMRR, offset voltage, off set current, Bias current, slow ratio
4. Oscillator a) RC phase shift
b) Wein Bridge
Design, out put wave form
5. Astable Multivibrator
Design, output wave form
6. Mono stable Multivibrator
Design, out put wave form
7. Schmitt trigger
Design, output wave form
8. Timer IC 555
Astable Multivibrator Design, out put wave form
9. Mono stable Multivibrator – Design, output wave forms
10. Voltage Regulators a) Fixed 78xx, 79xx
b) Variable 723
Calculation of regulation (load /line)
11. VCO – 566 IC
Design, output wave form
12. PLL NE 565 –characteristics
Lock range, capture range
13. Active filters 1st order LPF, HPF, BPF, Notch filter
Design, frequency response
14. Integrators & Differentiators
Design, waveforms

Text books

1. T.D. Kuryachan & Shyam Mohan S, "Electronics Lab Manual, Vol.II", Ayodhya Publications.

Semester : 5

Hrs/Week :3

Core course

Credits : 3

5B05ELE - NETWORK THEORY

Aim of the Course

To equip the students with basic knowledge in the Network theory

Objectives of the Course

- To learn the basics of Networks, Fourier series, Network theorems

Course Outline

Module I Basic circuit elements & wave forms – voltage & current sources – dependent sources - Kirchhoff's laws - series & parallel network – node & mesh analysis
Network theorems: superposition theorems – reciprocity theorems - Thevenin's - Norton's theorem (Millman's theorem) – maximum power transfer theorem.

Module II Transient and steady state Analysis: Time constant - sinusoidal steady state analysis – reactance – impedance – Admittance – Analysis of RC & RLC circuit – Q factor & Bandwidth - concept of fitter.

Module III Periodic and aperiodic wave forms – types of signals – Fourier representation of signals – Fourier transform – Laplace transform – properties – applications of Laplace transform.

Module IV Two port networks: Admittance parameters – impedance parameters – hybrid parameters – transmission parameters - relationship between parameter sets - attenuator – Lattice type – insertion loss.

Network function: Poles & zeros – pole zero plot - time domain behavior & transient response from pole zero plot - response due to sinusoidal input – magnitude & phase plot – Bode plots- stability - Routh Horvitz criteria of stability.

Text books

1. Network system – Roy Chowdhary

Reference books

1. Network theory – Van Valkenbug
2. Network, line & field - Ryder (PHI)

Semester : 5

Hrs/Week :3

Core course

Credits : 3

--5B06ELE – GENERAL INFORMATICS AND INFORMATICS SPECIFIC TO ELECTRONICS

Aim of the Course

To update and expand basic informatics skills and attitudes relevant to the emerging knowledge society and also to equip the students to effectively utilize the digital knowledge resources for their chosen courses of study.

Objectives of the Course

- To review the basic concepts & functional knowledge in the field of informatics.
- To review functional knowledge in a standard office package and popular utilities
- To create awareness about nature of the emerging digital knowledge society
- To create awareness about social issues and concerns in the use of digital technology
- To create awareness about major informatics initiatives in India and Kerala
- To impart skills to enable to students to use digital knowledge resources in learning.

Course Outline

MODULE I : OVERVIEW OF INFORMATION TECHNOLOGY Features of the modern Personal Computer and peripherals, Computer Networks & Internet, Wireless Technology, Introduction to Mobile Phone Technology, Introduction to ATM, Purchase of technology, license, guarantee, warrantee, Overview of Operating System & Major Application Software.

MODULE II : KNOWLEDGE SKILLS FOR HIGHER EDUCATION Data, Information and Knowledge, Knowledge Management- Internet as a Knowledge Repository, Academic Search Techniques, Creating your Cyber presence, Case Study of Academic web sites, Open Access initiatives, Open Access Publishing Models. Basic Concepts of IPR, Copy rights and Patents, Plagiarism, Introduction to use of IT in teaching and learning, case study of educational softwares. Academic services- INFLIBNET, NICNET, BRNET,

MODULE III : SOCIAL INFORMATICS IT & Society- Issues and concerns- Digital divide, IT & development, the free software debate, IT Industry: new opportunities and new threats, Cyber ethics, Cyber crime, Security, Privacy issues, Cyber laws, cyber addictions, Information overload, Health issues- guide lines for proper usage of computers, internet and mobile phones. E-wastes and green computing, Impact of IT on language & culture: localization issues- Unicode- IT and Regional Languages

MODULE IV : IT APPLICATIONS e-Governance applications at National and State level, IT for National Integration, Overview of IT application in Medicine, Healthcare, Business, Commerce, Industry, Defense, Law, Crime Detection Publishing, Communication, Resource Management, Weather forecasting, Education, Film and Media, It in service of disabled, Futuristic IT- Artificial Intelligence, Virtual reality, Bio-computing.

MODULE V : STREAM-SPECIFIC/SUBJECT- SPECIFIC MODULES

Introduction to LaTeX – Files – Text Modes – Commands for Text Mode – Lists – Centering and Underlining – Spacing – Tables – Sectioning and Cross – References – Commands for Math Mode – Numbered Equations – Subscripting and Superscripting – Text in Math Mode – Special Symbols. Introduction to MATLAB – MATLAB Characteristics – MATLAB Preliminaries – Rules on Variable and Function Names – Special Characters – Basic Arithmetic Operators – Elementary math Intrinsic Functions – File Types.

Text Books

- 1) Technology in Action, Pearson
- 2) V. Rajaraman, Introduction to Information Technology, Prentice Hall
- 3) Alexis Leon & Mathews Leon, Computers Today, Leon Vikas, Rs. 180
- 4) Hunt, Lipsman, Rosenberg, A Guide to Matlab, Cambridge

References

- 1) Greg Perry, SAMS Teach Yourself Open Office.org, SAMS
- 2) Alexis & Mathews Leon, Fundamentals of Information Technology, Leon Vikas
- 3) George Beekman, Eugene Rathswohl, Computer Confluence, Pearson Education
- 4) Barbara Wilson, Information Technology: The Basics, Thomson Learning
- 5) Ramesh Bangia, Learning Computer Fundamentals, Khanna Book Publishers
- 6) John Ray, 10 Minute Guide to Linux, PHI, ISBN 81-203-1549-9

Semester : 5

Hrs/Week :3

Core course

Credits : 3

5B07ELE - ELECTRONIC INSTRUMENTATION

Aim of the Course

To equip the students with a basic knowledge in Electronic Instrumentation

Objectives of the Course

- To learn the basics of electronic instruments
- To learn the basics of Transducers
- To learn the fundamentals of signal generators and biomedical instruments
-

Module I Introduction - General measurement system – characteristics - definition – static & dynamic transducers – different types - resistive transducer - strain gauge – capacitive - inductive transducers - LVDT (variable inductive transducers) piezo electric transducer – temperature transducers, thermo couple, thermisters – ultrasonic temperature transducer - photoelectric transducers.

Module II Signal conditioning (concept only) Bridges – Amplifier – chopper Amplifier – carrier amplifier - lock in Amplifier

Module III Electric instruments; Ammeter, voltmeter, Multimeter, different types signal generators, different types - cathode ray oscilloscope – frequency counters - logic analyser - spectrum analyser - recording instruments; X –Y recorder.

Module IV Biomedical instrumentation; Introduction - origin of bioelectric signals - Resting & Action potential – propagation, physiological transducers – active & passive transducer for medical application - diagnostic & Analytical equipments - ECG – EEG - PH meter colorimeter - therapeutic & imaging equipments - Ventilator, defibrillators - pace makers –X–ray machine - CT –ultrasound - principles of MRI - Laser applications.

Text books

1. Electrical & electronic Measurement & Instrumentation, Sawhney, Dhanpat Roy
2. Hand book of Biomedical Instrumentation, Khandpur – TMH

References

1. Modern electronic instrumentation & measuring technique, Hellfric & Cooper, PHI
2. Bio Medical Instrumentation -Leslie Chronell.

Semester : 5

Hrs/Week :3

Core course

Credits : 3

5B08ELE – MICROPROCESSORS

Aim of the Course

To equip the students with the basic hardware of computers

Objectives of the Course

- To learn the basics of Microprocessors, Microprocessor initiated operations
- To learn Assembly Language Programming techniques

Module I : Introduction Microprocessors – Introduction to 8085 - Microprocessors initiated operations & bus organisation – internal data operations – 8085 registers – externally initiated operation – memory organization –mapping & types- types of I/O addressing – memory mapped I/O – functional block – pin diagram – instructions & timing – instruction classification.

Module II : Programing & Architecture Data transfer operation – logical operation – instruction format – simple programs – instruction timing & operation status – instruction set of 8085 –programming technique – looping – 16 bit arithmetic instruction –memory related arithmetic instructions rotate –compare instruction – counters & time

delays - stack & subroutine - Interrupt – simple illustrative programs.

Module III : 8085 peripherals & 8086 architecture Introduction to programmable peripheral devices (8255A, 8254, 8257, RS 232) – over view of interfacing –introduction to 8086 - 8086 architecture – addressing modes

Module IV : Current trends Comparison of RISC & CISC – Introduction to Pentium processors – MMX technology - comparison between Microprocessor, Microcontroller & embedded system.

Text books

1. 8085 – Architecture programming & technique – Ramesh Goanker
2. Microprocessors & Interfacing - Programming & Hardware -- Douglas V Hall
3. Micro computer system – The 8086/8088 family Architecture Programming & Design – LIU. Y & Vibson-PHI

References

1. New processor & microcomputer-Based system Design, M. Rafiquezzman, CRC press.
2. 8086/8088 family design, Programming & Interfacing by John Utter Bra.

Semester : 5

Hrs/Week :4

Core course

Credits : 2

5B08PELE - MICROPROCESSOR LAB

1. Data transfer using direct & indirect addressing.
2. Block data transfer
3. Addition -8-bit, 16 bit
4. Subtraction -8 bit, 16 bit
5. Multiplication
6. Division
7. Array Addition
8. Logic operators – AND, OR, NOT
9. Binary to decimal & decimal to binary
10. Binary to BCD & BCD to binary
11. Largest & smallest from a set of numbers
12. Sorting (Ascending & descending)
13. BCD addition & subtraction
14. Up / down counter
15. Square wave generation

16. Stepper motor interfacing

17. Traffic light Interfacing.

Semester : 5

Hrs/Week :3

Core course

Credits : 3

5B09ELE - ELECTRONIC COMMUNICATION I

Aim of the Course

To equip the students with basic knowledge in Communication systems

Objectives of the Course

- To learn the basics of modulation basics of AM, FM, and PCM
- To learn the Digital modulation techniques

Module I Introduction – Messages & signals – Elements of communication systems – Modulation – Need for modulation- Amplitude modulation –Side band- AM signals & spectra, power relations, product modulator, single sideband AM –AM generation – High level & low level AM transmitters - AM receivers - Super heterodyne receivers – SSB generator balanced modulator -SSB transmitters –SSB receivers.

Module II Frequency modulation -FM & PM signals – spectra – Band with – narrow band & wide band FM – generation – direct FM – VCO – phase modulator – indirect FM – demodulation of FM- balanced discriminator, de-emphasis & pre-emphasis – FM transmitter & receivers – FM stereo transmission & reception.

Module III Sampling – Aliasing - PAM, PWM, PPM – concept of FDM & TDM, pulse code modulation – quantization – generation & reconstruction – companding, concept of ASK, FSK, PSK, DPSK.

Module IV Introduction to Antennas- Radiation mechanism– elementary doublet, folded dipole, Antenna gain & resistance – directional antennas – dipole Arrays, Yagi- Uda antenna

Text books

1. Electronic communication – Kennedy
2. Monochrome & color television – R.R .Gulathi

Reference

1. Electronic communication - Ruddy & Coolen
2. Antenna & wave propagation - K.D. Prasad

Semester : 5

Hrs/Week :4

Core course

Credits : 2

5B09PELE - COMMUNICATION SYSTEM LAB

1. AM generation
2. AM demodulation
3. Frequency response of IF amplifier
4. Mixer
5. Frequency modulation
6. Frequency demodulation
7. Balanced modulator
8. PAM
9. PAM demodulator
10. PWM
11. PWM demodulator
12. PPM
13. PPM demodulator
14. TDM.

Semester : 6

Hrs/Week :3

Core course

Credits : 3

6B10ELE - ELECTRO MAGNETIC THEORY

Aim of the Course

To equip the students with basic knowledge in E.M.Theory which is important in the field of communications.

Objectives of the Course

- To learn the Electrostatics, Magnetostatics and Electrodynamics

Module I Concept of Circuit & Fields, Vector Analysis, Physical interpretation of gradient, Divergence & curl, integral theorems & comparison

Module II Electrostatics : Introduction, fundamental relations of electro static field – Gauss’s law - special Gauss surfaces – the potential function, divergence theorem – Poisson’s & Laplace’s equation.

Magnetostatics : Biot – Savart law, force between two current carrying coils – Magnetic flux density, Magnetic field intensity, Intensity of Magnetisation - Ampere’s circuit theorem – Lorent’s force- Magnetic vector potential –Boundary conditions for magnetic fields.

Module III Electrodynamics: Faradays law of induction – modified Amperes law – Maxwell’s equation – wave equation – solutions of wave equation in free space –pointing vector- electromagnetic energy –Boundary conditions.

Module IV : Radiation & propagation of Radio waves: Radiation of electromagnetic fields – polarization –isotropic radiator –plane waves – electromagnetic spectrum – propagation of waves in free space – Ground wave propagation – sky wave- ionospheric propagation- critical frequency & maximum usable frequency – skip distance.

Text books

- 1) Electromagnetic waves & radiating systems – Jordan & Balmier -PH (New edition)

Reference

- 1) Fundamentals of Electrodynamics- Griffith (IV Edition)
- 2) Fundamental of electronic waves – Hugh Hildeeth skilling. Ane books
- 3) Fundamental of electromagnetics – Micah
- 4) Engineering electromagnetics- Haytt
- 5) Electromagnetic field theory fundamentals – BhagGuru & Hussein Hiziroglu- Cambridge.

Semester : 6

Hrs/Week :3

Core course

Credits : 3

6B11ELE - DIGITAL SIGNAL PROCESSING

Aim of the Course

To equip the students with basic knowledge in DSP

Objectives of the Course

- To learn the basics signals and analysis, Fourier transforms, digital filter design etc

Module I Introduction : Signals & systems -Analog, discrete & digital signals – concept of signal processing –Applications – comparison of Analog & digital signal processing. Fourier representation of analog & digital signals – Review of Laplace transform, Fourier transform, Z transform & their properties - discrete time sequences – time domain & frequency domain representation. **Analysis discrete time system** : Discrete time system – linear systems - time invariant systems - response of linear time invariant systems – convolution – stability & causality considerations – FIR systems – IIR systems – frequency responses

Module II Discrete Fourier transform & Fast Fourier transform : Introduction – Discrete Fourier series - discrete Fourier transform of finite duration sequences – properties of DFT – circular convolution - computation of DFT.

Fast Fourier transform : FFT Algorithms - general computational considerations – decimation in time & decimation in frequency algorithms – Radix 2 – FFT algorithms, quantization errors.

Module III Realization of digital systems : Recursive & non recursive systems – block diagrams & signal flow graphs – realization of IIR filters - direct form realization – cascade & parallel form realization – realization of FIR filters.

Module IV Digital filter design : IIR & FIR filters –design consideration – design of IIR filters – impulsive invariant transform – Bilinear transformation - digital Butter worth filters – design examples –design of FIR filters, windowing – hamming & hanning windowing.

Text books

1. Digital signal processing – Nagurkani
2. Digital signal processing - Rameshbabu

References

1. Digital signal processing - Salai Vahanan
2. Signals & systems – Sanjay Sharma.

Semester : 6

Hrs/Week :3

Core course

Credits : 3

6B12ELE - MICROWAVE TECHNIQUES AND RADAR

Aim of the Course

To equip the students with basic understanding of Microwave and Radar Engineering

Objectives of the Course

- To learn the basics of Micro waves and RADAR

Course Outline

Module-I Frequency spectrum ,Microwave bands, Applications of microwaves in different fields, wave guides – different types, transmission lines, types- parallel, co-axial, strip, optical & microwave guides, TE, TM & TEM waves, cut off frequency, phase & group velocities, Characteristics impedance, H- plane, E –plane & Magic Tees.

Module II Directional couplers, Isolators, circulators, Multicavity Klystron, reflex Klystron, Magnetrons, TWT – working principle & applications.

Module III Schottky diodes, point contact diodes, Varactor diodes, concept of parametric amplifier, IMPATT, TRAPATT & GUNN devices –Applications, Microwave antennas- (parabolic, lense, horn, slot)

Module IV Basic principle, fundamentals, performance factors, pulsed radar, Antennas & scanning, display methods, pulsed radar systems, MTI recons, CW Doppler radar, CW radar

Text books

1. Electronic communication system – Kennedy
2. Fundamental of Microwave engineering – Collins

References

1. Electronic communication, Roddy & Coolen,
2. Electronic & radio engineering, Terman
3. Principles of communication systems, Taub & Schilling

Semester : 6

Hrs/Week :3

Core course

Credits : 3

6B13ELE - ELECTRONIC COMMUNICATION II

Aim of the Course

To equip the students with detailed knowledge in Communication Channels, transmitters and receivers.

Objectives of the Course

- To learn the basics of Communication channels, transmitters, receivers

Course Outline

Module I : Optical fiber communication Optical fibers – structures & wave guiding fundamentals, fiber types – step index fiber structure - ray optics representation – wave equation for step index fiber, graded index structure - modes in graded index fibers optical communication & block diagram – overview attenuation – attenuation units - scattering & absorption losses – core & cladding losses – fiber materials & properties .

Module II : Television Broadcasting Elements of television systems – scanning - composite video signals – camera tubes – different types – principles of operation – picture tubes – vestigial side band - TV broadcasting –TV receivers –TV transmitters – sound & picture signal transmission - TV receivers – color Television, color TV camera –luminance signal - color picture tubes -Basic principle of color picture transmission & reception – concept of PAL systems.

Module III : Satellite communication Orbits – station keeping – altitude - transmission path – path loss – noise considerations – satellite systems- saturation flux density – isotropic radiated power multiple access method, concept of C band satellite receiving systems – Basic functions of various units -specification.

Module IV Noise – Frequency domain representation – source of noise –Thermal noise – shot noise - concept of noise band – width, noise figure - noise temperature – concept of information entropy – information rate – Shannon’s theorem – signal to noise ratio

Text books

1. Electronic communication S/m – Kennedy,
2. Monochrome of color Television - R.R Gulathi
3. Satellite communication – Dr. B.C. Agarwall
4. Optical fiber communication – Keiser.

Semester : 6

Hrs/Week :3

Core course

Credits : 3

6B14ELE – MICROCONTROLLERS

Aim of the Course

To equip the students with basic understanding of Microcontrollers and its applications

Objectives of the Course

- To learn the basics of microcontrollers

Course Outline

Module I : Introduction to Microcontrollers Comparison between microprocessor & microcontrollers -8051 microcontroller –architecture -8051 oscillator & clocks – program counter & data pointer - registers – Flags PSW – internal memory - internal RAM - stack & stack pointer – special function registers internal ROM – I/O pins –ports – external memory.

Module II : Peripherals Timer / counter interrupt – counting – serial data- i/p & serial data output – serial data interrupt –Data transmission & reception – serial data transmission mode. Timer flag interrupt - serial port interrupt – external interrupt – reset – interrupt priority – software generated interrupt.

Module III : Arithmetic & Logical operation Introduction - Addressing modes – Byte level logical operations - bit level logical operations – rotate & swap operation – simple programs.

Arithmetic operations: Introduction – flags - incrementing & decrementing – addition - subtraction – multiplication - division - simple programs.

Module IV : Instruction set Introduction –external data move - push & pop-data exchange – simple programs - jump -& call instructions – jump & call program range – jump & calls subroutine -Interrupt and returns – simple programs –keyboard interfacing - display interfacing – Seven segment & LCD display - D/ A and A/D interface – stepper motor interface.

Text books

1. Kenneth J. Ayala, “The 8051 microcontroller Architecture, programming & application”
2. Mohammad Ali Maszidi, “The 8051 microcontroller & embedded system”.

Semester : 6

Hrs/Week :4

Core course

Credits : 2

6B14PELE - MICROCONTROLLER LAB

1. Addition – 8 bit, 16 bit.
2. Subtraction – 8 bit, 16 bit.
3. Multiplication

4. Array addition (multibyte)
5. Logical Operations – AND, OR, NOT
6. Decimal to ASCII and ASCII to Decimal.
7. Decimal to Hexa and Hexa to Decimal.
8. Ascending Order.
9. Descending Order
10. Up/down Counter
11. Block data transfer
12. Interfacing with LCD.
13. Interfacing with Matrix Keypad.
14. Square wave generator
15. Interfacing with ADC.
16. Interfacing with DAC.
17. Digital Clock.
18. Interfacing with Stepper Motor.

Semester : 6

Hrs/Week :4

Core course

Credits : 4

6B15ELE – PROJECT WORK

Aim of the Course

To equip the students to carry out major research oriented project independently.

Objectives of the Course

- To learn to design new circuits according to the need and trouble shooting

Course Outline

Useful projects should be produced. Students are advised to search for better projects. Mere reproduction of available circuits may invite minimum credits. Projects must include electronic hardware and the demonstration is compulsory.

Sd/-
Dr.K.P.Santhosh,
Chairman,BOS Electronics(Cd)



KANNUR UNIVERSITY

**SCHEME & SYLLABUS
FOR**

**ELECTRONICS
(Complementary)**

CHOICE BASED CREDIT SEMESTER SYSTEM

w.e.f 2009 ADMISSION

Scheme Complementary (Electronics)

No	Semester	Course Code	Title of the Course	Hour/Week	Credit
1	I	1C01ELE	Basic Electronics	2	2
2	I	1C01PELE	Basic Electronics Lab	2	1
3	II	2C02ELE	Digital Electronics	2	2

4	II	2C02PELE	Digital Electronics Lab	2	1
5	III	3C03ELE	Communication System	3	2
6	III	3C03PELE	Electronic Circuits Lab	2	1
7	IV	4C04ELE	Microprocessor & Peripherals	3	2
8	IV	4C04PELE	Microprocessor Lab	2	1

Course objective

The main objectives to the B.Sc Electronics complementary course is to produce electronic specialists, who can be directly employed or start his/her own work as Electronic circuit Designer, Electronic consultant, Testing professional and Service engineers.

On completion of the B.Sc Electronics Complementary Course, the student will:

- Have sound knowledge of the theory behind the subjects like, Electronic components, Electronic measuring and testing instruments, Analog and Digital IC's, Electronic circuit design and implementation, Troubleshooting and maintenance of electronic and electrical devices.
- Have sound skills in assembly Language and High Level Language programming, Interfacing of electronic devices with computers, etc

Duration of the Complementary Course

Duration of the Programme shall be 4 semesters. Each semester should have 90 instructional days with 5 hours of instruction per day 5-days a week system. The University will conduct semester-end examinations. The practical examination shall be

conducted at the end of second and fourth semester. The Practical examinations for Odd semesters shall be conducted internally and Practical examinations for Even semesters shall be conducted externally by the University. The duration of both Theory and Practical examination shall be of three hours.

Semester : 1
Hrs/Week : 2
Complementary Course
Credits : 2

--1C01ELE - BASIC ELECTRONICS

Aim of the Course

To equip the students with basic components in electronics, identifying and testing them, to familiarize with various measuring and testing instruments and basic techniques of troubleshooting.

Objectives of the Course

- To learn the basics of electronic components
- To learn the basics of testing and measuring instruments
- To study circuit troubleshooting

Module I Introduction to electronics, applications ohm's law - Definitions – potential difference, current, voltage & its units, concept of voltage source & current source, Passive components, identification, colour coding. Introduction to semiconductor materials, metals, insulator, semiconductors doping, PN junction, majority & minority carriers, VI characteristics, reverse break down, Zener diode, LED

Module II Bipolar Junction Transistor – operation, configuration, input – output characteristic, parameters, MOSFET, CMOS. Comparison between BJT & FET

Module III Rectifiers - half wave, full wave. Ripple factor, efficiency, RC filter. Need for biasing, voltage divider biasing. RC coupled amplifier – working, frequency response. Operational amplifier - concept of 741 block diagram. Inverting & non inverting amplifier, applications

Module IV Concept of feed back – positive – negative .Feed back topologies, Sinusoidal oscillator – RC oscillator , Hartley oscillator, Colpits oscillator , Crystal oscillator. Multivibrators – Astable, Mono stable & Bi-stable multivibrators.

Text Books

- 1) Principles of electronics - V.K. Mehta
- 2) Basic electronics & linear circuits – N.N . Bhargava
- 3) Electronic device & circuit theory - Boylested & Neshelsky
- 4) Operational – Amplifier & Linear integrated circuits – Gaykwad .

References

- 1) [www. electronics – tutorials. Com](http://www.electronics-tutorials.com)
- 2) [www. electronics how stuff works . com](http://www.electronicshowstuffworks.com)
- 3) [www.science – e books . com / electronics.](http://www.science-ebooks.com/electronics)

Semester : 1

Hrs/Week :2

Complementary course

Credits : 1

1C01PELE – BASIC ELECTRONICS LAB

1. Familiarisation of components – Active, passive [symbols, identification, specification and testing]
2. Familiarisation of equipments – CRO, Voltmeter, Ammeter, Multimeter (Analog and digital), Function generator, Power supply
3. soldering and de soldering practices – Assembling hobby circuits
4. V-I characteristics of p-n junction diodes – germanium and silicon
5. V-I characteristics of LEDs
6. V-I characteristics of Zener diode
7. Characteristics of a transistor - common base configuration
8. Characteristics of a transistor - common emitter configuration,
9. Characteristics of FET
10. Half wave Rectifier (with and with out filters)
11. Full wave Rectifier (with and with out filters)
12. Zener voltage regulator (load & line regulations)

Semester : 2

Hrs/Week :2

Complementary course

Credits : 2

2C02ELE - DIGITAL ELECTRONICS

Aim of the Course

To equip the students with detailed knowledge in digital electronics, digital IC's in the 74XX series. Many of the ideas are important to learn microprocessors.

Objectives of the Course

- To learn different number systems, logic gates, comparators, flip flops etc

Course Outline

Module I Number systems – Decimal , Binary, octal & hexa decimal conversions, digital codes –BCD, excess – 3, gray code , ASCII code , Error detection codes conversions, Boolean Algebra & theorems, SOP & POS , De- Morgan's theorems , simplification of Boolean Algebra & K- map , Logic gates .

Module II Combinational circuits – Adders, Subtractors , Comparators, Decoders, Encoders, Mux & De – mux , parity generators – Familiarisation of popular ICs.

Module III Sequential circuits – Flip- flops (RS latch , Clocked RS ,D, J-K , T, Master slave), shift registers & applications , Asynchronous counter , Synchronous counter, Ring counter, counter design & sequence generator.

Module IV Converters – ADC & DAC [different types] working & applications, Display – LED (seven segment) & LCD.

Text books

1. Thomas Floyd – Digital fundamentals.

References

1. Digital principles & applications by Malvino & Leach
2. Digital electronics circuits & systems , V.K. Puri (TMH)
3. Taub & Schilling , Digital Integrated electronics
4. Millman – Digital Integrated circuits.

Semester : 2

Hrs/Week :2

Complementary course

Credits : 1

2C02PELE – DIGITAL ELECTRONICS LAB

1. Familiarization of logic gates
2. Realization of logic gates using universal gates
3. Implementation of half adders , Full adders using gates
4. Implementation of half subtractors and Full subtractors using gates
5. Implementation of Multiplexer & Demultiplexer (using IC)
6. Realization of S-R, J-K, D and T Flip flops (using gates)

7. Familiarization of S-R, J-K, D and T Flip flops (using IC)
8. Synchronous counter
9. Asynchronous counter
10. Ring counter & Johnson counter
11. Shift Registers
12. BCD to seven segment Decoder 7448

Semester : 3

Hrs/Week :3

Complementary course

Credits : 2

3C03ELE - COMMUNICATION SYSTEM

Aim of the Course

To equip the students with a basic knowledge in communication systems

Objectives of the Course

- To learn the basics of Communication systems

Course Outline

Module I Basic block diagram of a communication system, transmission media, Electro magnetic spectrum, uses of various frequency bands, modulation, demodulation, Need for modulation, Amplitude modulation – definition, modulation index, power relation, AM equation

Module II Frequency modulation , FM equation, comparison of FM & AM wide band - narrow band FM , pre – emphasis , De – emphasis , phase modulation – definition, equation .FM stereo - transmission & reception.

Module III Basic block diagram of AM transmitter, function of each block, AM receiver – block diagram, principle of super heterodyne receiver sensitivity, selectivity, block diagram of FM transmitter & receiver.

Module IV Pulse communication – basis of PAM, PWM, PPM - Digital communication - PCM, block diagram. bit rate, baud rate. Digital modulation schemes – ASK, FSK, PSK.modem.

Text Books

1. Electronic communication - Kennedy
2. Radio engineering - G.K.Mittel
3. Communication system – Kumar
4. Communication system – Roddy & Coolen
5. Data & computer communication – William Stallings
6. Data communications – William L Schweber.

Semester : 3

Hrs/Week :2

Complementary course

Credits : 1

3C03PELE - ELECTRONIC CIRCUITS LAB

1. RC Coupled Amplifier – gain and frequency response
2. RC Integrator and RC differentiator (using discrete component)
3. Astable multivibrator (using discrete component)
4. Monostable multivibrator (using discrete component)
5. RC Phase shift oscillator
6. Hartley and Colpitts Oscillator
7. Op-Amp – Non-Inverting and Inverting Amplifier
8. Adder and Subtractor using Op-Amp
9. Op-Amp parameters – CMRR, offset voltage, offset current, bias current, slow rate
10. AM generation and Demodulation

Semester : 4
Hrs/Week :3
Complementary course
Credits : 2

4C04ELE - MICROPROCESSOR & PERIPHERALS

Aim of the Course

To equip the students with a basic knowledge in microprocessors and peripherals

Objectives of the Course

To learn the basics of microprocessors, the heart of computers

Course Outline

Module I Microprocessor – Introduction to 8085, Bus organisation – Registers – Memory Organisation – I/O addressing.

Module II 8085 Architecture - functional blocks – instruction & timing – instruction classifications – word length – simple programs – instruction set of 8085 – Addressing modes.

Module III Looping – counting – indexing – simple illustrative programs – logical instruction – Branching instruction.

Module IV Introduction to programmable peripheral devices (8255A, 8254A, 8279 A) – Function of each chip – bus standards (serial & parallel) – RS 232 & USB – other processors – Features of Intel Pentium processors

Text books

1. Microprocessor Architecture, programming & application with 8085/8089,
A Ramesh .G. Gaonkar
2. Introduction to Microprocessor – Adithya. P. Mathew (TM)

Semester : 4
Hrs/Week :2
Complementary course
Credits : 1

4C04PELE - MICROPROCESSOR LAB

1. Addition 8 – bit ,16 bit
2. Subtraction 8 – bit , 16 bit

3. Block data transfer
4. Multiplication
5. Division
6. Logic operators -AND , OR , NOT
7. Binary to decimal & decimal to binary
8. Binary to BCD & BCD to binary
9. Largest & smallest from a set of numbers
10. Sorting - Ascending
11. Sorting - Descending
12. BCD addition and subtraction
13. Up/Down counter.

Sd/-
Dr.K.P.Santhosh,
Chairman,BOS Electronics(Cd)

SCHEME & SYLLABUS

FOR

COMMON COURSES (LRP Scheme)

CHOICE BASED CREDIT SEMESTER SYSTEM

w.e.f 2009 ADMISSION

Semester : 3

Hrs/Week :5

Common Course (for LRP Scheme)

Credits : 4

3A01ELE – NUMERICAL TECHNIQUES

Aim of the Course

To provide the students with a sound introduction of numerical methods as well as to make the learning a pleasurable experience

Objectives of the Course

- To enable the students to apply various methods of numerical computing to solve problems and make them better logicians.

Module I: Algorithmic approach to programming Algorithm – Description of algorithm – Narrative description – Flow chart – Tracing an algorithm – Summary of solution methodology

Module II: Roots of Transcendental Equation Solution by iteration – convergence criterion – order of convergence – Newton Raphson method – Bisection method – False position method

Module III: Interpolation and curve fitting Linear Interpolation – interpolating polynomials – Lagrange interpolating polynomial – difference calculus – Newton forward and backward difference formula – least square curve fitting (linear and nonlinear)

Module IV: Numerical Integration Trapezoidal and Simpson's methods – Newton Cotes methods – Gauss Quadrature

Ordinary differential equations Initial value problems – Euler's methods – Milne's method – Runge Kutta method.

Text Books

1. Shasry S.S, Introductory methods of Numerical Analysis, Prentice Hall
2. Jean Paul Tremblay & Richard B Blunt, An Introduction to Computer Science An algorithmic approach

References

1. E. Balaguruswamy, Numerical Methods, TMH
2. Scarborough, Numerical Mathematical Analysis, Oxford and IBH Publishing
3. William H Press, Saul A Teukolsky et al, Numerical Recipes in C, Cambridge University Press
4. Hiddebrand, Numerical Analysis, TMH

Semester : 3

Hrs/Week :5

Common Course(for LRP Scheme)

Credits : 4

3A02ELE – METHODOLOGY AND PERSPECTIVES OF SCIENCE

Aim of the Course

To introduce the methodology and perspective of Science in general so as to enable the students to systematically pursue his particular disciplines in science in relation to other disciplines that come under the rubric of sciences.

Objectives of the Course

On completion of the course, students

- will have learnt the fundamental characteristics of science as a human enterprise
- will be able to understand how science works
- will be able to apply scientific methods independently

Course Outline

Module I: Science and Science studies Types of knowledge: practical, theoretical and scientific knowledge, information – What is science, what is not science, laws of science. Basis for scientific laws and factual truths – Science as a human activity, scientific temper, empiricism, vocabulary of science, science disciplines. – Revolution in science and technology

Module II: Methods and Tools of Science Hypothesis, theories and laws in science, Observations, evidences and proof – Posing a question, formulation of hypothetico – deductive model, Inductive model. Signification of verification (proving), corroboration and falsification (disproving), auxillary hypothesis, ad-hoc hypothesis – Revision of scientific theories and laws – Importance of models, simulations and virtual testing – Mathematical methods versus Scientific methods – Significance of Peer Review

Module III: Experimentation in Science Design of an experiment, experimentation, observation, data collection, interpretation and deduction – Necessity of units and dimensions, repeatability and replication – Documentation of experiments, Record keeping. Connection between measurement and underlying theory – Types of experiments, Experiments to test a hypothesis, to measure a variable or to gather data by preliminary and explorative experiments – Planning of experiments, Design, selection of controls, observational requirements, instrumental requirements – Scientific instruments, Sensory extension, choice and selection of instruments, sensitivity of instruments, Accuracy, precision and errors, Types of instrumentation, Historical development and evolution of scientific instruments. Robotics

(Only a general orientation of scientific instruments required) – Making observations, direct and indirect observations, controlled and uncontrolled observations, human and mechanic observations, human error – Examples of great experiments in science *(To illustrate how various tools were applied to answer a question)*

Module IV: Data handling and ethics in science Documentation of experiments, Nature and types of data, typical examples, data acquisition, treatment of data, data interpretation, errors and inaccuracies – Data presentation: graphs, tables, histograms and pi diagrams – Ethics in Science, Scientific information, Depositories of scientific information, primary, secondary and digital sources, sharing of knowledge, transparency

and honesty, danger of preconceived ideas, Reporting of observational and experimental data, human bias, Biased observations, using and acknowledging observation by others. Publication and patents (Details not required) Plagiarism.

Text Books

1. Gieryn T F, Cultural Boundaries of Science, Univ. Chicago Press, 1999
2. Collins H and T Pinch, The Golem: What Everyone Should Know About Science, Cambridge Univ. Press
3. Hewitt, Paul G, Suzanne Lyons, John A, Suchocki and Jennifer Yeh, Conceptual Integrated Science, AddisonWesley, 2007
4. Newton R G, The Truth of Science, New Delhi, 2nd edition
5. Bass, Joel E et al, Methods of Teaching Science as Inquiry, Allyn & Bacon, 2009

Semester : 4

Hrs/Week :5

Common Course(for LRP Scheme)

Credits : 4

4A03ELE – CYBER LAWS & HUMAN RIGHTS

Aim of the Course

To equip the students with the basic knowledge of cyber laws, information technology act and human rights.

Objectives of the Course

- To learn the basics of digital convergence technology
- To create awareness among students about cyber crime laws and human rights.

Course Outline

Module I: Digital Convergences Evolution of digital technologies, computing, main frame era, PC. Digital convergence technologies-Compression technologies for the network Image compression, Audio Video compression, world Wide Web, Internet streaming media, Video conferencing, Internet telephony, message based communication, Digital television. Digital convergence- Human interaction, opportunities, empowering individuals and society, success stories

Module II: Digital divide and E-Governance Introduction- state as organization, New information technologies for Governance, Networking the civil society- Economics of development. Digital Divide- Society Knowledge matrix, Digital knowledge divides, local knowledge communities. E-Governance- Definition, Models, Opportunities- Health care, Teaching, Learning, Social Security net, Government identity number. Online

administration- A case study- A district online - district administration, Connecting to People, from poverty to power, Government at your doorsteps, Village to Village information corridors, performance governance

Module III: Cyber Crime Laws and Forensics Cyber Crime- Unauthorized computer access, data theft, data modification, data manipulation, threatening e-mails, ransom notes, credit card frauds, telecommunication frauds, computer aided drug trafficking, money laundering, software piracy, copy right violation etc.

Electronic Evidence- Digital forensics, Evolution of computer forensic procedures and tools, Acquisition of data, Data authentication and validation, Evidence recovery, Data analysis, e-mail tracking, Finding originating IP address.

GSM Mobile Phone Security- Subscribers identity Module (SIM) card, International Mobile Equipment Identity (IMEI) personal identification Number (PIN), Forensic analysis of GSM mobile phone.

Information Technologies Act- 2000 by Govt. of India creation and verification of digital signature, E-governances secure electronic records and secure digital signature, Regulation certifying authorities, IT offences, Cyber regulations appellate

Module IV: Human Rights Human Rights- meaning, origin, development of human rights in international base, Universal declaration of human rights. Implementation of human rights under Indian constitutions, women and human rights, children and human rights, Instruments for the protection of human rights and Rights protected - Human Rights commission and their powers.

Text Books

1. Digital convergence by Andy Cevell, Five wall media, New Delhi
2. Manual for investigation of computer related crimes by Ashok Dohare.
3. government@net_new government opportunities for India by Kiran Bedi, Parminder Jeet Singh, Sandeep Srivanthava:- Sage Publication, New Delhi

References

1. www.cyberforensics.in
2. www.mit.gov.in
3. www.digitaldivide.org/ -Digital Divide

Semester : 4

Hrs/Week :5

Common Course (For LRP Scheme)

Credits : 4

4A04ELE – PRINCIPLES OF MANAGEMENT

Aim of the Course

To equip the students with basic knowledge of four functions of management namely planning, organizing, leading and controlling which contribute to the success of a firm.

Objectives of the Course

- To learn the basics of various tools and techniques which employ effectively in managing the organization

Module I: Introduction to Management Functions and processor, Roles skills, Historic Evolution of Management, Organisational behaviours. Planning and Decision Making: Nature and forms of planning, strategic planning, decision making, the decision making process, manager as a decision maker. Types of decision, business forecasting & operation research

Module II: Organization Nature of organizations, principles, type of organizational structures, authority and responsibility, delegation and decentralization, informal organizations, group dynamics, staffing man power planning, recruitment, selection and placement, training and development, performance appraisal, wage payment plans, directing

Module III: Leadership Functions and models of leadership, motivational theories, effective communications, principles, managerial control, social responsibility of business, management of public enterprises

Module IV: Current Trends and Issues Globalization, diversity, IT, quality Management, Organizational culture and environment, Managing in a global environment understanding the global environment, managerial ethics

Text Books

1. PC Tripathi and P N Raddy, Prmapuer of Management 2nd edition TMH

References

1. Sleptin P Robins & Mary Coulter Management, Pearson Education
2. E.H. McGrath, Basic Managerial skill for All, PH1



KANNUR UNIVERSITY

SCHEME & SYLLABUS

FOR

OPEN COURSES

CHOICE BASED CREDIT SEMESTER SYSTEM

w.e.f 2009 ADMISSION

Scheme-Open Courses

No	Semester	Course Code	Title of the Course	Hours/ Week	Credit
1	V	5D01ELE	A.P C Hardware	2	2
2	V	5D02ELE	B.Opto electronics	2	2
3	VI	6D01ELE	A.Power electronics	2	2
4	VI	6D02ELE	B.Mobile Computing	2	2

Semester : 5

Hrs/Week :2

Open course

Credits : 2

5D01ELE – A.PC HARDWARE

Aim of the Course

To equip the students with a knowledge in computer hard ware and networking

Objectives of the Course

- To learn the basics of computer hardware and networking

Course Outline

Module I PC overview – block diagram – functional elements, CPU- Intel Pentium processors - CPU packages, internal cache – external cache – clock doubling, pipelining, CPU core voltages-motherboard architecture – form factors – AT X – NLX – BTX – chipsets

Module II Memory modules -DRAM, parity – RAM packagers - DDR – SDRAM, RDRAM, SIMM, DIMM ,RIMM Banking, installation of SIMM & DIMM, BIOS & CMOS setup – flash ROM, POST, COM, & LPT Ports ,USB ports, EISA, VESA, PCI, AGP, PC cards.

Module -III HDD,CD - ROMS, DVD , THUMP DRIVERS- WORKING & SPECIFICATIONS, HARD DISC interface like IDE, SCSI, SATA, AUTO detection, HARD disk installation, partitioning, high level formatting - sectors – clusters, FAT – fragmentation, ESDI, SVGA monitor – LCD - TFT monitor – working - specification.

Module IV Printers – dot matrix – Laser – inkjet – modems - & standards – lap top – batteries – Ni Cd – NiMH - Lithium ion batteries - power saving – blue tooth technology – frequency hopping – fire wire - WiFi, Power supply, SMPS–types – UPS - Scanners - Digital cameras, Key board, Mouse, Touch Pad

Text books

1. Structural organization, Andrew & Tanenbaum
2. Computer organization by John P . Hayes
3. PC Hard ware Computers : Craize zaker , & John Rourke
4. Computer organization – Hamach & zaky
5. Trouble shooting maintain & repairing & Stephen J Bigelaw
6. IBM clones -B Govinda Rajules

Semester : 5

Hrs/Week :2

Open course

Credits : 2

5D02ELE – B.OPTO ELECTRONICS

Aim of the Course

To equip the students with a basic knowledge in opto electronics devices

Objectives of the Course

- To learn the working of opto electronics devices
- To learn the basics of optical fiber communication

Course Outline

Module I Introduction- Nature of light - principle of operation of opto electronics devices - classification of opto electronics systems, Opto electronics system functions - transmission medium

Radiation sources- Radiometric sources-Photometric sources - incandescent lamp sources - modulation of light beam - Light emitting diodes, operating principle - different types - construction brightness control- spectral response-LED sources in optical communication-special features of LEDs, Lasers. Principle of lasers - different types, ruby lasers - gas lasers. Semiconductor lasers, heterojunction lasers - construction-operation - comparison with LED's

Module II Optical sensors, component matching- basic principle of operation of sensors-classification photoemissive cell - Spectral response- photo tube action – photomultiplier - Photoconductive devices – Review of photoconductivity- bulk type photoconductive cells-LDR - junction type photo conductive cells - different types of photodiodes - Photo transistor - Darlington photo transistors- photo FET, light activated SCR, desirable feature of photoconductive cells, photo voltaic cells, review of operating principle - important application - solar cell – construction - modes of operation - infrared detectors, ultraviolet detectors.

Module III Opto electronic couplers - principle of operation features at coupling efficiency-isolation voltage - different types of opto couplers, opto TRIAC, slotted opto couplers- reflective opto coupled SCR. Displays-LCD, principle of operation features-construction - application LED-seven segment display-vacuum fluorescent display-electro photo electric displays- applications

Module IV Opto electric system application - light beam alarms - industrial application - high speed counting - position detection - automatic inspection
Optical communication; basic principle of infrared communication and fiber optic communication

Text Books

1. Opto Electronic Circuits Manual R.M Marison

References

1. Fiber optic sensors – D.A Krohn (ISA)
2. Optical fiber communication- Kolser (Mc Graw Hill)

Semester : 6

Hrs/Week :2

Open course

Credits : 2

6D01ELE – A.POWER ELECTRONICS

Aim of the Course

To equip the students with a basic knowledge in power devices

Objectives of the Course

- To learn the working of power devices
- To learn the basics of inverters and static switches
- To learn the circuits dc choppers and power supplies

Module 1 : Power Semiconductor Theory and operations of SCR, UJT, DIAC & TRIAC – characteristics - design of relaxation oscillator using UJT - UJT in SCR & TRIAC triggering circuits- PUT'S- Silicon bilateral switch-speed control of DC shunt motor using thyristors – single phase half wave speed control systems- single phase speed control system-reversible control system.

Module II : Commutation Techniques Introduction –natural commutation-forced commutation - different types-self commutation, impulse commutation, resonant impulse commutation, External pulse commutation, complimentary commutation **Controlled Rectifiers:** Introduction- principle of phase controlled converter- Single phase series

Module III : Static switches Introduction-Signal phase AC switches- three phase AC switches- three phase switches- AC switches for BUS transfer-DC switches- solid state relays- AC voltage controller- principle of ON-OFF control- principle of phase control **DC Chopper:** Introduction-principle of step-down operation step down with RL load step-up operation switch mode regulator Buck Boost regulator, CUK regulator

Module IV : Inverters & Power supplies Introduction- principle of operation-Single phase bridge inverter- three phase inverter voltage control of single phase inverter - SMPS- Resonant DC power supply- Bi directional power supply- AC power supply.

Text Books

1. Power electronics, circuit Devices & Applications, M.H Rashid - PH

Reference Books

1. Power Electronics – P.S.Bimhra
2. Power Electronics& Controls – Sami K.Datte
3. Power Electronics & Regulator- IHRDE Publication

Semester : 6

Hrs/Week :2

Open course

Credits : 2

6D02ELE – B.MOBILE COMPUTING

Aim of the Course

To equip the students with a basic knowledge of mobile computing

Objectives of the Course

To introduce the concepts of emerging technologies in mobile computing

Course Outline

Module I Introduction- Mobility of Bits and Bytes- Wireless- The Beginning- Mobile Computing-Dialogue Control Networks-Middle and Gateways- Application and Services- Developing Mobile Computing Applications- Security in Mobile Computing- Standards-Standard Bodies-Players in the Wireless Space.

Mobile Computing Architecture- Internet- The Ubiquitous Network-Architecture for Mobile Computing- Three-Tier Architecture-Design Considerations for Mobile Computing- Mobile Computing Through Internet- Making Existing Application Mobile-Enabled-Multiple Access Procedures-Mobile Computing through Telephone-Developing an IVR Application-Voice XML-Telephony Application Programming Interface(TAPI)

Module II Emerging Technologies-Introduction-Bluetooth-Radio Frequency Identification (RFID)- Wireless Broadband (WiMAX) -Mobile IP-Internet Protocol Version 6(IPv6)-Java Card-Global System for Mobile Communication(GSM)-GSM Architecture-GSM Entities-Call Routing in GSM-GSM Address and Identifiers-Network Aspects in GSM-Authentication and Security.

Module III Short Message Service(SMS)-Mobile Computing over SMS-Value Added Services through SMS- Accessing the SMS Bearer-General Packet Radio Service (GPRS)- GPRS and Packet Data Network-GPRS Network Architecture-GPRS Network Operation-Data Services in GPRS- Application of GPRS-Limitation of GPRS.

Module IV Wireless Application Protocol-WAP - Application Environment-User Agent-User Agent Profile-Wireless Markup Language(WML)- WML Script- Wireless Telephone Application- WAP Push Architecture- Wireless Session Protocol (WSP)- Wireless Transaction Protocol- Wireless Transport Layer Security- Wireless Data Protocol-WAP Gateway- MMS – MMS Architecture- MMS Transaction Flows- SMIL-MMS Interconnection, Interoperability and Roaming- MMS Device Management and Configuration- GPRS Application.

Text Books

1. Asoke k Talukder, Toopa R Yavagal, Mobile Computing, TMH, 2005

Sd/-
Dr.K.P.Santhosh,
Chairman,BOS Electronics(Cd)

GENERAL PATTERN FOR B.Sc ELECTRONICS (Theory) QUESTION PAPER

Reg.No.....

Code No.

Name.....

First/Second/...../Sixth Semester B.Sc Degree Examination
Electronics (Core/Complimentary/Open)
2B02ELE – ELECTRONIC CIRCUITS

Time : 3 Hours

Maximum

Weightage : 30

Section A

(Answer all questions. Each question carries a weightage 1)

1. a)
.....
b).....
.....
c).....
.....
d).....
.....

2. a).....
.....
b).....
.....
c).....
.....
d).....
.....

- 3. a).....
.....
- b).....
.....
- c).....
.....
- d).....
.....

Section B

(Answer any 9 questions. Each question carries a weightage 1)

- 4.
.....
- 5.
.....
- 6.
.....
- 7.
.....
- 8.
.....
- 9.
.....
- 10.
.....
- 11.
.....
- 12.
.....
- 13.
.....
- 14.
.....
- 15.
.....

Section C

(Answer any 5 questions. Each question carries a weightage 2)

- 16.
.....
- 17.
.....
- 18.
.....
- 19.
.....
- 20.
.....
- 21.
.....

22.
.....

Section D

(Answer any 2 questions. Each question carries a weightage 4)

23.
.....

24.
.....

25.
.....

Note:

Section A Objective type questions

Section B Short answer type questions

Section C Short essay/problem solving type questions

Section D Essay type (long answer) questions

Reg.No.....

Code No.

Name.....

First Semester B.Sc Degree Examination

Electronics (Core)

1B01ELE – METHODOLOGY AND THEORY OF ELECTRONIC DEVICES

Time : 3 Hours

Maximum

Weightage : 30

Section A

(Answer all questions. Each question carries a weightage 1)

- 1 (a) Which is the most commonly used semiconductor material?
(b) Energy band gap of Germanium at room temperature is of the order of -----
(c) The merging of a free electron and a hole is called -----
(d) Give the full form of UJT

2. (a) Write the colour code of a 1k Ω resistor
(b) An ac voltage can be converted in to a unidirectional voltage by using a ----- circuit
(c) The ripple factor of a full wave rectifier is -----
(d) Give the full form of PIV in rectifier service

3. (a) Operating point in the load line gives the zero signal value of V_{CE} and -----
(b) For active operation of a transistor the collector base junction should be -----

- (c) In the case of a JFET, the $V_{GS\ off}$ is numerically equal to ----
(d) Write the full form of JFET

Section B

(Answer any 9 questions. Each question carries a weightage 1)

4. Define ohms law?
5. Draw the energy band diagram of conductor, insulator and semiconductor.
6. List out the any two characteristics of ideal diode?
7. Draw the circuit diagram of transistor common collector configuration?
8. Define Pinch off voltage?
9. List out any two application of thyristors?
10. Define KVL?
11. Define Dynamic resistance of diode?
12. State and explain Barkhausen criterion for oscillation
13. What is biasing ? Why it is needed ?
14. Explain the characteristics of a zener diode
15. Describe the action of a MOS capacitor

Section C

(Answer any 5 questions. Each question carries a weightage 2)

16. Explain 'open' and 'short' in series circuits? Define Fermi level? And also draw the Fermi level of intrinsic semiconductor.
17. Differentiate Avalanche and Zener breakdowns.
18. Explain the construction and working of PNP transistor?
19. Compare the FET over BJT.
20. Discuss thermal runaway. How it can be prevented in a high power transistor and heat sink
21. For an n-channel JFET, $I_{DD} = 10\text{mA}$, $V_p = 4.2\text{ V}$. Calculate the drain current I_D at $V_{GS} = -2\text{V}$
22. A 6.2V zener diode along with a series resistance is connected across a 20V dc supply. Calculate the minimum value of series resistance, if the maximum zener current is 25mA

Section D

(Answer any 2 questions. Each question carries a weightage 4)

23. With the help of suitable sketch explain the behavior of a PN junction under Forward and Reverse biasing and also explain the V-I characteristics of PN junction.

24. Explain Transistor common emitter configuration with necessary diagrams?
25. Describe the construction, operation and characteristics of enhancement MOSFET?

Reg.No.....

Code No.

Name.....

Second Semester B.Sc Degree Examination
Electronics (Core)
2B02ELE – ELECTRONIC CIRCUITS

Time : 3 Hours

Maximum

Weightage : 30

Section A

(Answer all questions. Each question carries a weightage 1)

1. a. An ac current given by $i=14.14\sin(\omega t+\pi/6)$ has an rms value of
Ampere
b. A sine wave has a frequency of 50HZ.Its angular frequency israd/sec.
c. P.I.V of centre tapped full wave rectifier is.....
d. Rectification efficiency of bridge rectifier is.....
2. a. An amplifier circuit of voltage gain 100 gives 2V output. The value of input voltage
is.....
b. Voltage gain of emitter follower is.....
c. Unit of mutual conductance is.....
d. What do you mean by fidelity of an amplifier?
3. a. When a negative feedback is applied input impedance is increased by a factor
of.....
b. Voltage gain of positive feedback amplifier is given by the equation, $A_f=$
.....
c. In power amplifiers..... provides impedance matching.
d. When a transistor is said to be in a quiescent state?

Section B

(Answer any 9 questions. Each question carries a weightage 1)

4. Define PIV of a rectifier?
5. Draw the circuit diagram of a two stage RC coupled Amplifier?
6. Define positive feedback and also list out its application?
7. Draw the equivalent circuit of a Crystal oscillator?
8. Draw the circuit diagram and wave form of a +ve clamper?
9. List out the advantage of Full wave Bridge Rectifier over centre-tapped rectifier?
10. What is the need of Transistor biasing?
11. What is the significance of stability factor?
12. What is the use of filter?
13. What are parameters of JFET?
14. What are the different types of feedback circuits?
15. Explain CLC filter.

Section C

(Answer any 5 questions. Each question carries a weightage 2)

16. Define the following: i. RMS value ii. Average value
17. Write a short note on following,
 i. Voltage and current gain ii. Input and output resistance
18. A power transistor working in Class A operation has Zero signal power dissipation of
 25 watts. If the AC output power is % watts, find:
 i. Collector efficiency ii. Power rating of transistor
19. Define oscillator? List out the conditions for oscillation, and also list out different
 types of transistor oscillator
20. Write a short note on differentiator and integrator?
21. Differentiate the voltage and power amplifier.
22. The RC network of a weinbridge oscillator consists of resistors and capacitors of
 values $R_1=R_2=220K\Omega$ and $C_1=C_2=250pF$. Determine the frequency of oscillation

Section D

(Answer any 2 questions. Each question carries a weightage 4)

23. Draw the circuit of a RC coupled amplifier and explain its working.
24. Discuss the effect of negative feedback in amplifiers.
25. What is the principle of operation of a crystal oscillator? Derive the equation for frequency of oscillation.

Reg.No.....
 Name.....

Code No.

Third Semester B.Sc Degree Examination Electronics (Core) 3B03ELE – DIGITAL ELECTRONICS

Time : 3 Hours
 Weightage : 30

Maximum

Section A

(Answer all questions. Each question carries a weightage 1)

1. a) $Y = A B + A \bar{B}$ is the output of a----- gate.
 b) The switching time of a Schottky TTL 54 S / 74 S is ----- than the 54 H/ 74 H series.
 c) If n flip flops are arranged in such a way that the output of one flip flop as the clock of the next flip flop, a frequency division of ----- is achieved.
 d) ----- is an example of GPIB.
2. a) Define speed/power product of a logic circuit. Give its unit.
 b) What is a Schottky MOS gate?
 c) What is a bidirectional shift register?
 d) What is a modem?

3. a) Draw the circuit diagram using OR gates to obtain the output ABC .
- b) How will you use a flip flop as a memory device. ?
- c) Implement half adder using gates.
- d) Give any two applications of GPIB

Section B

(Answer any 9 questions. Each question carries a weightage 1)

4. Simplify the expression $A+AB+ABC$
5. Find out the decimal value of 11101.011
6. Define fanout
7. Define noise margin
8. Explain parity checker
9. Compare multiplexers and demultiplexers
10. Draw the logic circuit of gated D-latch
11. What are edge-triggered flip flops?
12. Explain DAC
13. Draw the diagram of serial in-parallel out shift register
14. How many seconds are required to shift a 12-bit number in to a serial 12-bit shift register if the clock is 1MHz
15. What is a mod-3 counter?

Section C

(Answer any 5 questions. Each question carries a weightage 2)

16. Explain DeMorgan's theorem
17. Explain a TTL gate
18. Explain decimal to BCD encoder
19. Explain edge-triggered JK flip flop
20. Explain a four-bit parallel in serial out shift register
21. Explain a two-bit asynchronous binary counter
22. With the help of symbolic diagram explain how a multi emitter transistor can be used
as a 3- input TTL gate.

Section D

(Answer any 2 questions. Each question carries a weightage 4)

23. Explain the concept of SOP and POS with an example

24. Explain four-bit synchronous decade counter

25. Explain up/down counter

Reg.No.....

Code No.

Name.....

Fourth Semester B.Sc Degree Examination
Electronics (Core)
4B04ELE – ANALOG INTEGRATED CIRCUITS

Time : 3 Hours

Maximum

Weightage : 30

Section A

(Answer all questions. Each question carries a weightage 1)

1. a) The 741 is a monolithic IC constructed by a special process called -----
 - b) The CMRR of an ideal op-amp is-----
 - c) The gain of a summing amplifier is-----
 - d) The positive feedback is mostly used in ----- circuits.
2. a) The gain limiting frequency of practical integrator is -----
 - b) ----- is the Figure of Merit of a narrow band pass filter.
 - c) The procedure used to convert an original cut off frequency to a new one is known as -----
 - d) The gain roll of rate for a second order filter is -----
3. a) The phase shift oscillator consists of -----sections of RC network.
 - b) -----oscillator is suitable for generating frequency from 10 HZ to 1 MHZ.
 - c) ----- is known as sine to square wave converter.
 - d) The oscillator whose output frequency depends on the amplitude of the input voltage is known as -----

Section B

(Answer any 9 questions. Each question carries a weightage 1)

4. Define the terms Slew rate and SVRR?
5. Define the terms Lock Range and Capture Range stage of PLL?
6. State the advantages of 555 timers?
7. Define Q factor?
8. Differentiate linear and switching regulators?
9. Define Oscillator? Classify?

10. Draw the circuit diagram of Zero crossing detector?
11. What is the application of Sample and Hold circuit?
12. What are the advantages of active filters over passive filters?
13. Explain the squaring circuit using a multiplier.
14. What are the important characteristics of a comparator?
15. What are the applications of a balanced modulator?

Section C

(Answer any 5 questions. Each question carries a weightage 2)

16. Explain about the basic building blocks of an op-amp.
17. Explain the importance of instrumentation amplifier with circuit diagram?
18. Explain the principles of switching regulators?
19. Explain Narrow Band Reject Filter with the help of necessary diagrams?
20. Write short note on fixed voltage regulators?

21. Draw and explain the working of a differentiator with neat circuit diagram and waveforms?
22. Briefly explain voltage follower?

Section D

(Answer any 2 questions. Each question carries a weightage 4)

23. With the help of neat circuit diagram and waveforms explain the working of 555 timers as an Astable Multivibrator?
24. Draw the circuit diagram of a Dual Input Balanced Output Differential Amplifier and obtain expressions for its voltage gain, input resistance and output resistance?
25. Explain the working of Schmitt trigger with suitable diagram?

Reg.No.....
Name.....

Code No.

Fifth Semester B.Sc Degree Examination
Electronics (Core)
5B05ELE – NETWORK THEORY

Time : 3 Hours
Weightage : 30

Maximum

Section A

(Answer all questions. Each question carries a weightage 1)

1. a) A periodic signal $f(X)$ can be equated to....., the time period is given as P
b) The period of $\cos nx$ and $\sin nx$ is
- c) If $r(t)$ is a ramp signal, then for $(t \geq 0)$, $r(t)=\dots\dots\dots$
d) Laplace transform of t^n is given by.....
2. a) Inverse Laplace transform of $s / (s^2 + a^2)$ is given by.....
b) Two resistors R_1 and R_2 are connected in series and a voltage V is applied across it.
The voltage drop across R_2 is given by the formulae.....
c) Thevenin's theorem states that any linear dc circuit can be replaced by an equivalent circuit
consisting of one voltage source inwith one resistance.
d) Opposition to passage of AC due to capacitance and inductance is called.....
3. a) In impedance parameters Z_{11} is termed as
b) In admittance parameters Y_{12} is termed as
c) Transmission parameters are otherwise called.....
d) In hybrid parameters Y_{21} is termed as

Section B

(Answer any 9 questions. Each question carries a weightage 1)

4. Explain various types of signals.
5. List two properties of Laplace transform.
6. Find the Laplace transform of $\cos^2 2t$
7. Mention various types of dependent sources. Draw the symbols.
8. State Miller's theorem.
9. State maximum power transfer theorem
10. Define bandwidth of filters

11. Draw the equivalent circuit for hybrid parameters
12. Define poles and zeros of network function
13. Deduce an expression for the current in an inductive circuit
14. Explain about impulse function
15. Explain how time behaviour can be obtained from the pole-zero plot of a network

Section C

(Answer any 5 questions. Each question carries a weightage 2)

16. Find the Fourier series expression of $(\pi - x^2)/4$, $0 < x < 2\pi$
17. State and explain Norton's Theorem
18. Find the branch currents in the circuit shown in below, using Nodal analysis

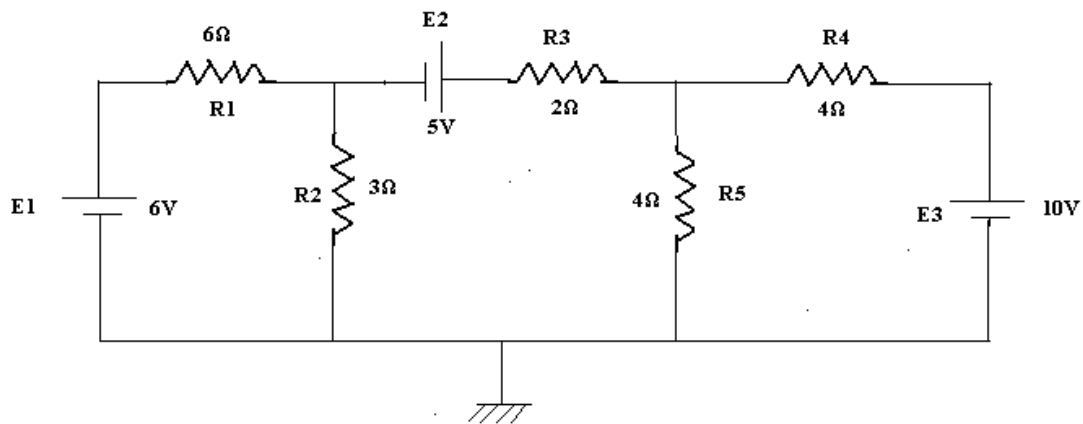

19. Derive the expressions for Y-parameters
20. Derive the expressions for Z-parameters in terms of hybrid and transmission parameters
21. Explain various types of filters
22. Analyze whether the system with the following characteristic equation is stable or not.

$$S^2 + 2S^5 + 8S^4 + 12S^3 + 20S^2 + 16S + 16 = 0$$

Section D

(Answer any 2 questions. Each question carries a weightage 4)

23. Find Thevenin's equivalent circuit across AB in the following circuit,

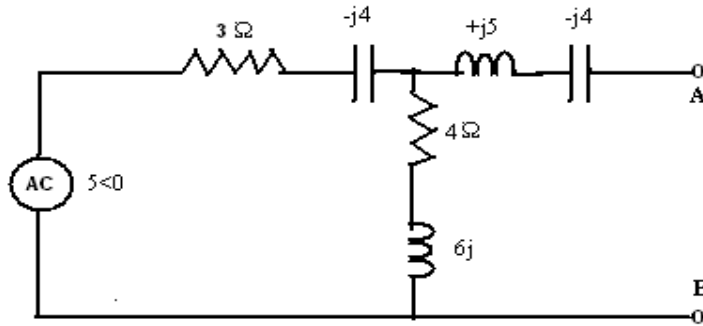

24. Explain in detail the attenuator, its units and classification

25. Determine the stability of a system using Routh's criterion. Its characteristic equation is $s^6 + 2s^5 + 8s^4 + 12s^3 + 16s^2 + 16 = 0$

Reg.No.....

Code No.

Name.....

Fifth Semester B.Sc Degree Examination
Electronics (Core)
5B07ELE – ELECTRONIC INSTRUMENTATION

Time : 3 Hours

Maximum

Weightage : 30

Section A

(Answer all questions. Each question carries a weightage 1)

- 1
 - a) LVDT is a transducer.
 - b) Micro phone is an example oftransducer.
 - c) Thermister havetemperature coefficient of resistance.
 - d) Quartz crystal belongs to the category of transducer.

- 2
 - a) The heart of an Oscilloscope is.....
 - b) Ammeter movement with full scale deflection current of $50\mu\text{A}$ has a sensitivity of
 $\text{K}\Omega/\text{V}$

- c) The CRO provides a..... dimensional visual display of the of the signal wave shape on its screen.
- d) The D'Arsonval meter movement can be converted into an audio frequency ac ammeter by adding ato it.
- 3 a) The operation of a Q meter is based on
- b) A high input-resistance voltmeter has loading effect.
- c) A VOM is used for measuring voltage, current and
- d) In a linear meter, half scale deflection occurs when there is percent of rated current through its coil

Section B

(Answer any 9 questions. Each question carries a weightage 1)

4. What is a transducer?
5. Explain the procedure to select a transducer
6. What is a piezo electric transducer?
7. What are the applications of wave analyzer
8. What is a chopper amplifier?
9. Write short notes on signal generator
10. What is a frequency counter?
11. What is a bioelectric signal?
12. Explain term polarization and depolarization
13. What are ventilators?
14. Distinguish between ECG and EEG
15. Briefly discuss the functioning of a potentiometric recorder

Section C

(Answer any 5 questions. Each question carries a weightage 2)

16. Explain Lock in amplifier
17. Write a short essay on signal conditioning
17. What are the applications of x-y recorder?
19. Explain active and passive transducer in detail
20. What is a Pace maker? What are the different types of pacemaker?
21. A $3\frac{1}{2}$ digit voltmeter is used for measuring voltage (i) find the resolution of the instrument (ii) How would a voltage of 15.72V be displaced in 10V range? (iii) How would a voltage of 10.735V be displaced on 100V range?

22. A resistive strain gauge with a gauge factor of 2 is cemented to steel member, which is subjected to a stress of 10^8N/m^2 . The modulus of elasticity of steel is approximately $2.0 \times 10^{11} \text{N/m}^2$. If the original value of the gauge resistance is 125 ohm, calculate the original resistance

Section D

(Answer any 2 questions. Each question carries a weightage 4)

23. Discuss the classification of Transducers. Explain the construction and working of a digital displacement Transducer.

24. Briefly explain the functioning of X-Y recorders, Strip chart recorders and compare it.

25. Describe the working of single-phase half bridge inverter with necessary circuit diagram.

What is its main drawback? Explain how this drawback is overcome?

Reg.No.....
Name.....

Code No.

Fifth Semester B.Sc Degree Examination
Electronics (Core)
5B08ELE – MICROPROCESSORS

Time : 3 Hours
Weightage : 30

Maximum

Section A

(Answer all questions. Each question carries a weightage 1)

1. a) ----- is a Basic Element of memory
b) -----is a Logic circuit that amplifies current or power.
c) POP is an instruction related with ----- operation
d) The Address Bus is -----.
2. a) INTnn is ----- interrupt
b) 10.8086 has ----- one bit flags
c) 12.8086 has ----- multiplexed address and data bus
d) The assembler ----- is written by Intel for the 8086 microprocessor
3. a) The term superscalar refers to the microprocessors architecture that includes more than
----- execution unit
b) Intel 80186 has ----- bit data bus
c) 9.8088 Microprocessor is internally divided into two separate functional unit----

d) Programming technique that used to instruct the microprocessor to repeat task is called

Section B

(Answer any 9 questions. Each question carries a weightage 1)

4. Explain memory mapped I/O technique with the help of STA instruction?
5. Explain the functions of ALE and IO/M signal of the 8085 microprocessor?
6. What is subroutine explain?
7. Give notes on modes of 8254? Mention different modes?
8. Give notes on BIU?
9. Give notes on interrupts in 8086?
10. What is string? Give an example?
11. Give notes on CALL and RET instruction in 8086?
12. Mention the advanced design features of Intel Pentium processor?
13. Give notes on difference between RISC and CISC processors?
14. How 16 bit data is stored in 8085?
15. Mention the advanced design features of Intel Pentium processor?

Section C

(Answer any 5 questions. Each question carries a weightage 2)

16. Give notes on interrupts in 8085?
17. Explain the working of RS232?
18. Discuss in detail the flags used in 8086?
19. With an example discuss the WHILE –DO statement in 8086?
20. Discuss the super scalar architecture? Give example?
21. With neat structure explain the working of USB?
22. What is instruction cycle? Explain with example.

Section D

(Answer any 2 questions. Each question carries a weightage 4)

23. With a neat sketch explain the architecture of 8085?

24. With a neat sketch explain the 8255A?
25. With a neat sketch explain the architecture of 8086?

Reg.No.....

Code No.

Name.....

**Fifth Semester B.Sc Degree Examination
Electronics (Core)**

5B09ELE – ELECTRONIC COMMUNICATION I

Time : 3 Hours

Maximum

Weightage : 30

Section A

(Answer all questions. Each question carries a weightage 1)

1. a) Modulation in excess of _____ percent produces distortion.
b) In SSB-SC transmission, bandwidth required is _____ of that required for normal AM transmission
c) The most commonly used filter in SSB generator is _____ ?
d) In communication system noise is most likely to affect the signal at _____ ?
2. a) A pre-emphasis circuit provides extra noise immunity by _____
b) An FM signal with a deviation δ is passed through a mixer and has its frequency reduced five fold. The deviation in the output of the mixer is.....
c) The modulation index of an FM transmission can never _____ its deviation ratio.
d) The FM frequency remains _____ ?
3. a) Quantizing noise occurs in?
b) The biggest disadvantages of PCM is?
c) The most common modulation system used for telegraphy is
d) FSK is a system of..... modulation

Section B

(Answer any 9 questions. Each question carries a weightage 1)

4. What are the different needs for modulation?
5. How can we use a transistor to obtain a amplitude modulated wave.
6. Derive the frequency spectrum of a AM wave.
7. Explain the circuit that can be used to suppress the carrier signal in an AM wave.
8. Explain any one circuit that can be used for unwanted sideband suppression.
9. Explain vestigial side band transmission.
10. Derive the equation for a FM wave modulation index.
11. Explain the Armstrong method for FM generation.
12. Explain Noise figure.
13. Define polarization with diagram?

14. Compare ASK, FSK, PSK.
15. Define amplitude modulation & modulation index?

Section C

(Answer any 5 questions. Each question carries a weightage 2)

16. Explain with the aid of wave forms, how a grid modulated class C amplifier generates AM.
17. Explain with wave forms how a suitable train of current pulses fed to a tuned amplifier will result in a AM output wave.
18. Explain PWM with relevant diagrams.
19. Explain how carrier recovery takes place in ASK demodulator
20. What are the basic properties of ionospheric layers?
21. Derive maximum usable frequencies (MUF) and secant law
22. Explain DPSK with relevant diagrams

Section D

(Answer any 2 questions. Each question carries a weightage 4)

23. Explain with neat diagram, the working of a balanced modulator and super heterodyne receiver
24. Explain about FM transmission and reception
25. Explain, with suitable diagram, yagi-uda antenna, directional antennas & resonant antennas.

Reg.No.....

Code No.

Name.....

**Sixth Semester B.Sc Degree Examination
Electronics (Core)
6B10ELE – ELECTRO MAGNETIC THEORY**

Time : 3 Hours

Maximum

Weightage : 30

Section A

(Answer all questions. Each question carries a weightage 1)

1.
 - a) Poisson's equation in vacuum is called equation.
 - b) The unit of electric susceptibility is
 - c) Gauss theorem relates surface integral to integral
 - d) Stoke theorem relates line integral tointegral.
2.
 - a) The value of permeability is given by
 - b) Biot savarts law indicates the strength at any point.
 - c) Magnetic flux density over a closed path is

- d) Relation between magnetic flux and induced voltage is given as
3. a) Isotropic antenna is aantenna.
 b) The wavelength of the dipole antennae is
 c) The current fed to the elements in a broad side array antenna is
 d) Power radiated per unit area in any direction is given by.....

Section B

(Answer any 9 questions. Each question carries a weightage 1)

4. Explain the force on a moving charge.
5. Explain the force on a differential current element.
6. Explain B H M.
7. Explain hysteresis.
8. Explain Amperes work law
9. State and explain Maxwell's first law.
10. State and explain Maxwell's fourth law

11. What is the physical interpretation of gradient?
12. What is the physical interpretation of divergence?
13. State and Explain stokes theorem.
14. What do you mean by effective length of an antenna?
15. Explain gain of an antenna.

Section C

(Answer any 5 questions. Each question carries a weightage 2)

16. Explain polarization of a wave.
17. Derive the Poisson and Laplace equations
18. Derive an expression for the force between two current carrying conductors
19. State and Explain pointing theorem.
20. Write a note on Hall effect
21. Derive the relation between E and H for a uniform planar wave
22. Briefly explain the directivity of an antenna.

Section D

(Answer any 2 questions. Each question carries a weightage 4)

23. Derive the divergence and curl of a unit volume in spherical and cylindrical coordinate systems.

24. Derive a relation between electric displacement and displacement density.
25. Derive the Maxwell's equation in integral, derivative forms and in statement forms

Reg.No.....
Name.....

Code No.

Sixth Semester B.Sc Degree Examination
Electronics (Core)
6B11ELE – DIGITAL SIGNAL PROCESSING

Time : 3 Hours
Weightage : 30

Maximum
Section A

(Answer all questions. Each question carries a weightage 1)

1. a) A system is said to be _____ if it obeys the principle of superposition.
b) If $X(Z)$ is the Z-transform of $x(n)$, the Z-transform $\{nx(n)\}$ is _____.
c) The discrete time version of ramp function is defined by _____.
d) A system is said to be _____ if the output does not depends on future inputs & outputs.
2. a) Define DFT of a discrete time sequence.
b) For a 32 point sequence $x(n)$, in the direct computation of DFT, $X(k)$ the number of complex multiplications required for each value of k is _
c) Draw the basic butterfly structure in Radix-2 DIT-FFT algorithm
d) In an LTI system if input has N_1 samples and impulse response has N_2 samples then the output will have _____ samples.
3. a) Define recursive system.
b) What are the basic elements used for the realization of filters?
c) Write general equation, which represent a FIR system.
d) An LTI system is unstable if the impulse response is_____.

Section B

(Answer any 9 questions. Each question carries a weightage 1)

4. What is down sampling?
5. Define a signal
6. Define FIR system

7. What is an energy system?
8. Define IDFT.
9. What is phase factor or twiddle factor?
10. What is DIT radix -2 FFT?
11. Define a recursive and non recursive system
12. How will you choose the order N for a butter worth filter.
13. What is bilinear transformation?
14. What is the relation between digital & analog frequency in impulse invariant transformation?
15. What are the advantages & disadvantages of digital filter?

Section C

(Answer any 5 questions. Each question carries a weightage 2)

16. Compare analog, discrete and digital signals.
17. Determine the system is linear or not. $y(n)=x(n)+1/x(n-1)$
18. Perform circular convolution of the two sequences $x_1(n)=\{2,1,2,1\}$
 $x_2(n)=\{1,2,3,4\}$
19. Compare the DIT and DIF radix -2 FFT.
20. An LTI system is described by the difference equation $y(n)=a_1y(n-1)+x(n)+b_1x(n-1)$.
 Realize it in direct form – I structure and convert to direct form –II structure.
21. Compare IIR and FIR filters.
22. Given that $H_a(S) = 1/(S+1)$. By impulse invariant methods obtain the transfer function and difference equation of digital filter.

Section D

(Answer any 2 questions. Each question carries a weightage 4)

23. An 8 point sequence is given by $x(n)=\{2,2,2,2,1,1,1,1\}$. Compute 8 point DFT of $x(n)$ by Radix-2 DIT-FFT algorithm.

24. Obtain the cascade form realization of the LTI system governed by the equation $y(n) = (-3/8)y(n-1) + (3/32)y(n-2) + (1/64)y(n-3) + x(n) + 3x(n-1) + 2x(n-2)$
25. Convert the analog filter with system function $H_a(S)$ into digital filter using bilinear transformation. $H_a(S) = (S+0.3)/(S+0.3)^2 + 16$

Reg.No.....

Code No.

Name.....

**Sixth Semester B.Sc Degree Examination
Electronics (Core)**

6B12ELE – MICROWAVE TECHNIQUES AND RADAR

Time : 3 Hours

Maximum

Weightage : 30

Section A

(Answer all questions. Each question carries a weightage 1)

1. a) The lowest TM mode in a rectangular waveguide of cross-section $a \times b$ with $a > b$ will be _____
- b) What is the reflection coefficient of a transmission line with a VSWR of 2?
- c) In E plane Tee, output in the two arms are _____ degree out of phase.
- d) Which transmission line is ideal for handling high power?

2. a) Which mechanism is used in a parabolic reflector in order to allow the feed to be placed at a convenient point?
- b) _____ microwave diode is suitable for very low power oscillations only.
- c) The abbreviation TRAPPAT stands for _____.
- d) Which diode is used for electronic tuning at microwave frequency?

3. a) Which modulation technique is used in A - Scope display?
- b) A system that gives the angular position of the target accurately is said to be _____ in that angle.
- c) The maximum range of a radar is proportional to the square root of the _____ area of the antenna

d) In a CW doppler radar, which component is used to provide isolation between the transmitter and receiver?

Section B

(Answer any 9 questions. Each question carries a weightage 1)

4. What are the advantages of microwaves in communication?
5. Define TEM, TE, TM waves.
6. Write the general wave equations.
7. Define stub matching.
8. Write short notes on microstrip lines
9. Write short notes on impedance matching.
10. What is a magic Tee? Explain.
11. Give the application of a TWT.
12. Why do we use strapping in a magnetron
13. Explain the VI characteristics of a tunnel diode.
14. What are the applications of varactor diodes?
15. What do you mean by the power range equation of radar?

Section C

(Answer any 5 questions. Each question carries a weightage 2)

16. Explain the construction and working of schottky barrier diode.
17. Explain the working of TRAPATT diodes
18. Explain mode jumping in magnetron
19. Give the physical interpretation of phase and group velocity.
20. Explain the working of the multi cavity klystron
21. Explain the Modulators used in Radar systems.
22. Explain CW Doppler Radar.

Section D

(Answer any 2 questions. Each question carries a weightage 4)

23. Describe the structure of TWT and its characteristics; then explain how it works.

24. Explain about different types of microwave antennas.

25. With a neat block diagram, explain MTI radar.

Reg.No.....

Code No.

Name.....

Sixth Semester B.Sc Degree Examination

Electronics (Core)

6B13ELE – ELECTRONIC COMMUNICATION II

Time : 3 Hours

Maximum

Weightage : 30

Section A

(Answer all questions. Each question carries a weightage 1)

1. a) _____ is the principle behind Optical fibre communication.
b) PIN photo diodes have the advantage of small value of the _____ capacitance.
c) Ruby lasers are usually excited by a _____ flash lamp.
d) The unit of luminous flux is _____
2. a) A color burst has a frequency of _____ MHz
b) The aspect ratio for a standard 625 –B system is _____
c) Y signals are also called _____
d) The number of frames per second in TV System in India is _____
3. a) A satellite orbit is _____ if the orbit plane coincides with the reference plane of the primary body.
b) The equipment that carries out modulation and demodulation is called _____
c) The most important sources of noise in the receiver is the _____ in its pre amplifier
d) The Synchronous satellite used for communication are widely called _____ Satellites.

Section B

(Answer any 9 questions. Each question carries a weightage 1)

4. Differentiate between step index and graded index fiber.
5. Explain Scattering and absorption losses
6. Explain Thermal noise and shot noise.
7. Explain the concept of noise band width.
8. State Shannon's theorem.
9. Give wave equation for step index fibre
10. Explain cladding losses
11. Give properties of fibre material
12. Give basic principle of colour picture transmission

13. Give notes on scanning
14. Give basic principle of colour picture reception
15. What is saturation flux density

Section C

(Answer any 5 questions. Each question carries a weightage 2)

16. Explain an image Orthicon Camera tube.
17. Give notes on vestigial side band transmission. Also give notes on demerits of VSB transmission
18. With simple block diagram explain a monochrome TV transmitter.
19. Explain different types of orbit in satellite Communication
20. Explain the concept of C band satellite receiving system.
21. Write a short note on Thermal noise and shot noise.
22. Explain the concept of noise band width

Section D

(Answer any 2 questions. Each question carries a weightage 4)

23. Explain Optical Communication System with neat block diagram.
24. Explain different types of orbits and Path losses in Satellite communication.
25. Explain Source of noise and signal to noise ratio.

Reg.No.....

Code No.

Name.....

**Sixth Semester B.Sc Degree Examination
Electronics (Core)
6B14ELE – MICROCONTROLLERS**

Time : 3 Hours

Maximum

Weightage : 30

Section A

(Answer all questions. Each question carries a weightage 1)

1. a) The size of the internal RAM is.....
b) Address of stack when the 8051 is reset.....
c)The signal that reads internal ROM is.....
d)The address of PCON special function register is.....
2. a)There are Programmable modes for serial data communication
b) The non-maskable interrupt of 8051 is.....

- c) For a higher priority interrupt bit is set to..._.....
 - d) The address of the interrupt program for INTO level generated interrupt is
3. a) XRL A,#n means xor each bit of A with
- b) Swap exchange low and high in a byte.
 - c) The mnemonic for immediate data is the
 - d) The mnemonic of Boolean operator NOT is

Section B

(Answer any 9 questions. Each question carries a weightage 1)

4. Compare Micro Controller and Micro Processor
5. Briefly explain the concept of flags in 8051
6. What are timers/counters?

7. What are interrupts? Mention its various types.
8. What is meant by register addressing modes? Give one example.
9. Mention the Arithmetic Operators (Opcodes)
10. Briefly explain Jump Instruction.
11. What is meant by Push and Pop instructions?
12. What is meant by Bounce and Key held?
13. Mention and briefly explain Control Lines of LCD.
14. List the different types of opcodes used
15. What is the use of stack in subroutines?

Section C

(Answer any 5 questions. Each question carries a weightage 2)

16. Explain IO Ports in 8051. Draw the PIN Configuration for Port 0 and Port 3.
17. What are Timers? Explain the timer modes of operation.
18. Explain the interrupts in 8051.
19. What is meant by Addressing Modes? Explain different types with one example.
20. Explain Call and Subroutine concepts.
21. Explain ADC and DAC.
22. Write a program to swap two numbers.

Section D

(Answer any 2 questions. Each question carries a weightage 4)

23. With a neat diagram, explain the architecture of 8051.
24. Write a program to find the largest and smallest numbers from an array.

25. What is interfacing? Explain the process of interfacing of Micro Controller and Stepper

Motor with a neat Diagram

Reg.No.....

Code No.

Name.....

**Fifth Semester B.Sc Degree Examination
Electronics (Open)**

5D01AELE – P C HARDWARE

Time : 3 Hours

Maximum

Weightage : 30

Section A

(Answer all questions. Each question carries a weightage 1)

1. a) ----- helps main processor in carrying out video or graphic related operations.
 - b) AMD stands for-----
 - c) -----Printers print one character at a time, with print head moving across the line.
 - d) The ROM contains a short program called----- which reads the boot record from disk and store in main memory.
2. a) PC/XT is a ----- Computer.
 - b) The common bus type LAN also known as-----.
 - c) ----- is the high bus for the display Boards.
 - d) URL stands -----.
3. a) Full form of VIRUS.
 - b) ----- permits outside access to internet files by hiding behind a security system.
 - c) Give an example for a 32 –bit Processor.
 - d) MMX stands for-----.

Section B

(Answer any 9 questions. Each question carries a weightage 1)

4. Explain the functional Units of a PC?
5. Write short note on SIMM, DIMM and RIMM?
6. Explain types of VIRUS?
7. Explain Bluetooth Technology?
8. Describe the various communication medias for networks?
9. State the current System configuration?
10. Write short notes on SMPS and UPS?
11. Describe the working of Key Board?
12. What is meant by CPU over-clocking? Explain the features
13. Compare the characteristics and specifications of different monitors.
14. Give short notes on CPU batteries.

15. Compare IDE, SCSI and SATA drives

(Answer any 5 questions. Each question carries a weightage 2)

16. Explain the features of Pentium Processors?

17. Write short note on PCI Bus with a neat diagram?

18. Explain the working of DVD ROM?

19. Discuss the different types of Scanners?

20. Explain the working of any Laser Printers?

21. Explain the Various Network Topologies?

22. Discuss the features and specifications of fire-wire technology

Section D

(Answer any 2 questions. Each question carries a weightage 4)

23. Explain the characteristics of different memory modules.

24. You are given a new hard disk drive. Explain the different steps involved in the preparation

and installation of the hard disk.

25. Compare the specifications and characteristics of different printers and their interfaces.

Reg.No.....

Code No.

Name.....

Fifth Semester B.Sc Degree Examination Electronics (Open) 5D01BELE – OPTO ELECTRONICS

Time : 3 Hours

Maximum

Weightage : 30

Section A

(Answer all questions. Each question carries a weightage 1)

1. a) The source of energy which maintains the medium in the population inverted state is called _____.
- b) _____ is a junction formed between two dissimilar semiconductors.
- c) Which type of laser produces pulses of visible light at a wavelength of 694.3 nm?
- d) The Acronym LASER stands for _____.

2. a) The large resistance of the photoconductive cell when it is not illuminated is called its _____.
- b) Which arrangement is used to provide complete electrical isolation between the control circuit and the load in an LASCR?
- c) 1 lumen = _____ mW
- d) Solar Energy converter is usually constructed in the form of a _____ with a very thin layer of P material at its surface.

3. a) Which method is used to alter light properties in a Liquid Crystal display?
- b) In opto coupler, the ratio of photo transistor current to LED is called _____.
- c) What is electroluminescence?
- d) Dynamic scattering LCD is operating in _____ mode of LCD display.

Section B

(Answer any 9 questions. Each question carries a weightage 1)

4. What is Infrared communications?
5. What do you mean by high speed counting?
6. What is the principal advantage of an LED display? What are the principal limitations?
7. What is opto triac? Explain.
8. What is spontaneous emission and stimulated emission?
9. Compare LED with LASER.
10. How carrier confinement and photon confinement are achieved in hetero junction semi conductor devices?
11. Explain the working of Darlington photo transistors
12. Give the principle of infrared communication
13. What is meant by optical pumping?
14. Give note on infrared detectors
15. Briefly explain the features of reflective opto coupled SCR

Section C

(Answer any 5 questions. Each question carries a weightage 2)

16. Explain the basic principle of operation of an optical isolator.
17. A series/parallel array of solar cells is used to provide power to a certain load. The array consists of 12 parallel branches, each of which has 8 cells in series. If each cell produces 900 mA at 0.55 V, how much power is delivered to the load?
18. Explain about the applications of photo voltaic cells.
19. Each LED in a certain seven segment display draws 20 mA and has 1.5V drop when it is illuminated. Which numeral (from 0 through 9) requires the most power to

display? The least power?

20. Give a short note on optical communication link.

21. What is the principal advantage of an LED display? What are the principal limitations?

22. What is opto triac? Explain.

Section D

(Answer any 2 questions. Each question carries a weightage 4)

23. Explain the operation principle of LASER as optical source.

24. Describe about different types of light sensors and its applications.

25. What are the different types of displays used in opto electronics? Explain in detail.

Reg.No.....

Code No.

Name.....

**Sixth Semester B.Sc Degree Examination
Electronics (Open)**

6D02BELE – MOBILE COMPUTING

Time : 3 Hours

Maximum

Weightage : 30

Section A

(Answer all questions. Each question carries a weightage 1)

- 1 (a) you have tape drives rated for 24GB, which is actually a -----
 (b) First, the ----- developed the wireless communication through line and sight.
 (c) By the ----- communication satellites are commercialized.
 (d) Mobile computing device need not to be -----.
2. (a) Write the full form of IVR
 (b) Recently computer networks have evolved by leaps and -----
 (c) GPS-enabled device can obtain latitude and longitude with accuracy of about 1-5 m.
 (d) Give the full form of GPS
3. (a) -----is a communication service standardized in the GSM mobile communication system.
 (b) Short messages between the SMSC and the handset is done using the -----
 (c) The ability to route data directly through -----
 (d) Write the full form of EMI.

Section B

(Answer any 9 questions. Each question carries a weightage 1)

- (a) What are the functions used in MMS Interconnection.
5. Describe the Security in Mobile Computing.
6. Explain Mobile Computing based on Telephone system.
7. List out two interface application in Telephony system.
8. Briefly explain the Mobile Computing through Internet services.
9. Explain the basic idea in Radio Frequency Identification.
10. Write short notes on Wireless Broadband.
11. Explain the 6th version of IP-Internet Protocol.
12. Write a short note on Mobile Communication system.
13. Give any two applications in GPRS.
14. What are the limitations in GPRS?
15. What is the purpose of using Mobile Computing?

Section C

(Answer any 5 questions. Each question carries a weightage 2)

16. Explain the Data Services in GPRS
17. Write short notes on GPRS Network Operation
18. Write the Value Added Services in SMS
19. Describe the WAP Application.
20. Sketch out neatly the WAP Push Architecture?
21. Give brief notes on MMS Architecture
22. Explain briefly about the SMIL

Section D

(Answer any 2 questions. Each question carries a weightage 4)

23. Discuss with neat illustration about the Bluetooth Technology.
24. Give in detailed about the Architecture of the GPRS Network.

25. Describe the application and details of the WAP Environment.

Reg.No.....

Code No.

Name.....

First Semester B.Sc Degree Examination
Electronics (Complementary)
1C01ELE – BASIC ELECTRONICS

Time : 3 Hours

Maximum

Weightage : 30

Section A

(Answer all questions. Each question carries a weightage 1)

- 1 (a) Which is the most commonly used semiconductor material?
(b) Energy band gap of Germanium at room temperature is of the order of -----
(c) The merging of a free electron and a hole is called -----
(d) Give the full form of UJT
2. (a) Write the colour code of a $1k\Omega$ resistor
(b) An ac voltage can be converted in to a unidirectional voltage by using a ----- circuit
(c) The ripple factor of a full wave rectifier is -----
(d) Give the full form of PIV in rectifier service
3. (a) Operating point in the load line gives the zero signal value of V_{CE} and -----
(b) For active operation of a transistor the collector base junction should be -----
(c) In the case of a JFET, the $V_{GS\ off}$ is numerically equal to ----
(d) Write the full form of JFET

Section B

(Answer any 9 questions. Each question carries a weightage 1)

4. Define ohms law?
5. Draw the energy band diagram of conductor, insulator and semiconductor.
6. List out the any two characteristics of ideal diode?
7. Draw the circuit diagram of transistor common collector configuration?
8. Define Pinch off voltage?
9. List out any two application of thyristors?
10. Define KVL?
11. Define Dynamic resistance of diode?
12. State and explain Barkhausen criterion for oscillation
13. What is biasing? Why it is needed ?
14. Explain the characteristics of a zener diode
15. Describe the action of a MOS capacitor

Section C

(Answer any 5 questions. Each question carries a weightage 2)

16. Explain 'open' and 'short' in series circuits? Define Fermi level? And also draw the Fermi

level of intrinsic semiconductor.

17. Differentiate Avalanche and Zener breakdowns.

18. Explain the construction and working of PNP transistor?

19. Compare the FET over BJT.

20. Discuss thermal runaway. How it can be prevented in a high power transistor and heat sink

21. For an n-channel JFET, $I_{DD} = 10\text{mA}$, $V_p = 4.2\text{ V}$. Calculate the drain current I_D at $V_{GS} = -2\text{V}$

22. A 6.2V zener diode along with a series resistance is connected across a 20V dc supply.

Calculate the minimum value of series resistance, if the maximum zener current is 25mA

Section D

(Answer any 2 questions. Each question carries a weightage 4)

23. With the help of suitable sketch explain the behavior of a PN junction under Forward and

Reverse biasing and also explain the V-I characteristics of PN junction.

24. Explain Transistor common emitter configuration with necessary diagrams?

25. Describe the construction, operation and characteristics of enhancement MOSFET?

Reg.No.....

Code No.

Name.....

Second Semester B.Sc Degree Examination Electronics (Complementary) 2C02ELE – DIGITAL ELECTRONICS

Time : 3 Hours

Maximum

Weightage : 30

Section A

(Answer all questions. Each question carries a weightage 1)

- a) $Y = A B + A \bar{B}$ is the output of a----- gate.

b) The switching time of a Schottky TTL 54 S / 74 S is ----- than the 54 H/ 74 H series.

c) If n flip flops are arranged in such a way that the output of one flip flop as the clock of the next flip flop, a frequency division of ----- is achieved.

d) ----- is an example of GPIB.
- a) Define speed/power product of a logic circuit. Give its unit.

b) What is a Schottky MOS gate?

c) What is a bidirectional shift register?

- d) What is a modem?
- 3. a) Draw the circuit diagram using OR gates to obtain the output ABC.
- b) How will you use a flip flop as a memory device?
- c) Implement half adder using gates.
- d) Give any two applications of LCD

Section B

(Answer any 9 questions. Each question carries a weightage 1)

- 4. Simplify the expression $A+AB+ABC$
- 5. Find out the decimal value of 11101.011
- 6. Define fanout
- 7. Define noise margin
- 8. Explain parity checker
- 9. Compare multiplexers and demultiplexers
- 10. Draw the logic circuit of gated D-latch
- 11. What are edge-triggered flip flops?
- 12. Explain DAC
- 13. Draw the diagram of serial in-parallel out shift register
- 14. How many seconds are required to shift a 12-bit number in to a serial 12-bit shift register if the clock is 1MHz
- 15. What is a mod-3 counter?

Section C

(Answer any 5 questions. Each question carries a weightage 2)

- 16. Explain DeMorgan's theorem
- 17. Explain a TTL gate
- 18. Explain decimal to BCD encoder
- 19. Explain edge-triggered JK flip flop
- 20. Explain a four-bit parallel in serial out shift register
- 21. Explain a two-bit asynchronous binary counter
- 22. With the help of symbolic diagram explain how a multi emitter transistor can be used
as a 3- input TTL gate.

Section D

(Answer any 2 questions. Each question carries a weightage 4)

- 23. Explain the concept of SOP and POS with an example

24. Explain four-bit synchronous decade counter
25. Explain up/down counter

Reg.No.....
Name.....

Code No.

Third Semester B.Sc Degree Examination
Electronics (Core)
3C03ELE – COMMUNICATION SYSTEM

Time : 3 Hours
Weightage : 30

Maximum
Section A

(Answer all questions. Each question carries a weightage 1)

1. a) Modulation in excess of _____ percent produces distortion.
b) In SSB-SC transmission, bandwidth required is _____ of that required for normal AM transmission
c) The most commonly used filter in SSB generator is _____ ?
d) In communication system noise is most likely to affect the signal at _____?
2. a) A pre-emphasis circuit provides extra noise immunity by _____
b) An FM signal with a deviation δ is passed through a mixer and has its frequency reduced five fold. The deviation in the output of the mixer is.....
c) The modulation index of an FM transmission can never _____ its deviation ratio.
d) The FM frequency remains _____?
3. a) Quantizing noise occurs in?
b) The biggest disadvantages of PCM is?
c) The most common modulation system used for telegraphy is
d) FSK is a system of..... modulation

Section B

(Answer any 9 questions. Each question carries a weightage 1)

4. What are the different needs for modulation?
5. How can we use a transistor to obtain a amplitude modulated wave.
6. Derive the frequency spectrum of a AM wave.
7. Explain the circuit that can be used to suppress the carrier signal in an AM wave.
8. Explain any one circuit that can be used for unwanted sideband suppression.
9. Explain vestigial side band transmission.
10. Derive the equation for a FM wave modulation index.
11. Explain the Armstrong method for FM generation.
12. Explain Noise figure.

13. Define polarization with diagram?
14. Compare ASK, FSK, PSK.
15. Define amplitude modulation & modulation index?

Section C

(Answer any 5 questions. Each question carries a weightage 2)

16. Explain with the aid of wave forms, how a grid modulated class C amplifier generates AM.

17. Explain with wave forms how a suitable train of current pulses fed to a tuned amplifier will result in a AM output wave.

18. Explain PWM with relevant diagrams.

19. Explain how carrier recovery takes place in ASK demodulator

20. How PCM signals are generated?

21. Derive maximum usable frequencies (MUF) and secant law

22. Explain DPSK with relevant diagrams

Section D

(Answer any 2 questions. Each question carries a weightage 4)

23. Explain with neat diagram, the working of a balanced modulator and super heterodyne receiver

24. Explain about FM transmission and reception

25. Explain the different types of Digital modulation techniques

Reg.No.....

Code No.

Name.....

Fourth Semester B.Sc Degree Examination

Electronics (Complementary)

4C04ELE – MICROPROCESSOR & PERIPHREALS

Time : 3 Hours

Maximum

Weightage : 30

Section A

(Answer all questions. Each question carries a weightage 1)

1. a) Size of data bus in 8085 is -----
- b) The result of any arithmetic operation is stored in -----
- c) PSW stands for -----

- d) SID pin is used for -----
- 2. a) After executing MOV A,M the content of accumulator is -----
- b) The accumulator is cleared by the instruction -----
- c) Carry flag is not affected by the instruction-----
- d) Opcode Fetch Cycle takes -----
- 3. a) CPI 0A instruction compares 0 A with the contents of -----
- b) CALL instruction is associated with -----
- c) The number of T-states required for JNC 8005 if CY=1 is -----
- d) ORA A makes the contents of Accumulator -----

Section B

(Answer any 9 questions. Each question carries a weightage 1)

- 4. What are flags? Mention their uses
- 5. How 16 bit data is stored in 8085?
- 6. What is immediate addressing mode?
- 7. What do LHLD and SHLD instructions do?
- 8. How data is compared in 8085?
- 9. What are the conditional Jump instructions in 8085?
- 10. What is BSR mode?
- 11. What is the function of 8254 IC?
- 12. Mention the advanced design features of Intel Pentium processor?
- 13. Explain memory mapped I/O technique with the help of STA instruction?
- 14. Explain the functions of ALE and IO/M signal of the 8085 microprocessor?
- 15. What is string? Give an example?

Section C

(Answer any 5 questions. Each question carries a weightage 2)

- 16. Explain the register structure of 8085.
- 17. What are the addressing modes in 8085? Explain.

18. Explain the working and uses of Logical instructions?

19. How interrupts are handled using 8259?

20. What is instruction cycle? Explain with example.

21. Explain the working of RS232?

22. With neat structure explain the working of USB?

Section D

(Answer any 2 questions. Each question carries a weightage 4)

23. Explain the internal architecture of 8085.

24. Write a program to sort a list of numbers.

25. With a neat sketch explain the 8255A?

Reg.No.....

Code No.

Name.....

First Semester B.Sc Degree Electronics Examination, March 2009

Common Course

3A01ELE – NUMERICAL TECHNIQUES

Time : 3 Hours

Maximum

Weightage : 30

Section A

(Answer all questions. Each question carries a weightage 1)

1. a) The method ofis called interpolation

- b) method is also known as binary chopping method
- c)interpolating formula can be used to find non tabular values at the beginning of the table.
- d) The Gaussian Quadrature formula for $n = 2$ is given as
2. a)method is also called method of tangents
- b) is known as debugging
- c) interpolating formula can be used for data of unequal intervals
- d) Order of convergence of false position method is
3. a) In fourth order Runge Kutta method slopes atpoints are taken.
- b) Order of convergence denotes how fast theprocess converges.
- c) Modified Euler's method is also known asorder Runge Kutta method
- d) The error committed in Simpson three-eight rule is

Section B

(Answer any 9 questions. Each question carries a weightage 1)

16. Explain algorithm and flow chart.
17. Why the proper choice of initial guess is very important in Newton Raphson method
18. Write a difference table for a polynomial function $f(x)$, if 6 values of x and $f(x)$ are tabulated at equal intervals
19. What is interpolation? What methods are available for interpolation?
20. Explain empirical laws and curve fitting
21. Write down the general formula for solving differential equation by Euler's method. What are the disadvantages of Euler's method?
22. What is a transcendental equation? What are its characteristics
23. What is the principle of least square regression
24. State the formula used in Milne Simpson method
25. What is an initial value problem? How it is different from a boundary value problem?
26. How is Newton's interpolation formula better than Lagrange formula
27. What is curve fitting

Section C

(Answer any 5 questions. Each question carries a weightage 2)

26. Find the real roots of the equation $x=e^{-x}$ using Newton Raphson method
27. Find the cubic polynomial which takes the following values:
 $y(0)=1, y(1)=0, y(2)=1, y(3)=10$ also compute $y(4)$
28. Evaluate $\int_0^1 \frac{1}{1+x} dx$ using trapezoidal rule with the intervals of width $h=0.5$ and
 $h=0.25$
29. Given $\frac{dy}{dx} = y - x, y(0)=2$. Find $y(0.1)$ and $y(0.2)$ correct to four decimals places
 using Runge Kutta fourth order formulas
20. Explain the principle of bisection method with help of an illustration
21. Derive Simpson's three-eighth's rule
22. Derive normal equations for evaluating the parameters a and b to fit the data to power function model of the form $y=ax^b$

Section D

(Answer any 2 questions. Each question carries a weightage 4)

23. What is meant by interpolating polynomials? Obtain the Newton's forward difference interpolation formula
24. Explain the Simpson's 1/3 rd rule for numerical integration
25. Explain the iteration method for finding the root of an equation of the form $x = \phi(x)$. Discuss the criterion for convergence

Reg.No.....
Name.....

Code No.

Second Semester B.Sc Degree Examination, March 2009
Electronics
Common Course

4A03ELE – CYBER LAWS AND HUMAN RIGHTS

Time : 3 Hours

Maximum

Weightage : 30

Section A

(Answer all questions. Each question carries a weightage 1)

- 1 (a) Computers are now an ----- part of the lives of human beings.
- (b) The history of computers is the year-----.
- (c) The ENIAC 1 requires 20,000 ----- to operate.
- (d) One of the most important aspects of computers today was invented in -----

2.(a) Write the full form of SIP.

(b) ----- is simply the number of bits per second that can be sent through a given medium

(c) Telephone companies are replacing old ----- with new fiber-optic.

(d) New technologies, such as ----- are being developed to protect intellectual property.

3. (a) In 1995 ----- releases the first commercial Internet phone software.

(b) Tell some available Internet telephony applications.

(c) Because of the ----- efficiency and low costs that VoIP technology can provide

(d) Write the full form of VoIP.

Section B

(Answer any 9 questions. Each question carries a weightage 1)

4. Explain the basic idea in PSTN and mobile network providers

5. Write a short note on Government identity number.

6. Explain the basis of Village-to-Village information corridors

7. How will Digital knowledge divide local knowledge communities?

8. What are the limitations in Data analysis?

9. What is the purpose of using Digital forensics?

10. Write short notes on e-mail tracking

11. Write note on data modification.

12. How will you find the telecommunication frauds?

13. How to find the originating IP address

14. Explain briefly about the Regulation certifies authorities

15. What are the functions in the development of human rights?

Section C

(Answer any 5 questions. Each question carries a weightage 2)

16. Describe the importance of E-Governance in Teaching.

17. Briefly explain the Networking the civil society.

18. Discuss the importance of E-Governance in health care.

19. Write a short note on online administration

20. Explain about the Networking the civil society.

21. Give brief notes on secure digital signature

22. Give short notes on Human Rights commission and their powers.

Section D

(Answer any 2 questions. Each question carries a weightage 4)

23. Explain briefly about the Digital convergence.

24. Illustration with neat sketch Digital television about the Bluetooth Technology.

25. What is "digital convergence," and how will it change delivery systems for media?

Sd/-

**Dr. K P Santhosh,
Chairman, BOS Electronics (Cd)**